



MVHR

Effective systems for healthiness
in residential environment



TEKNOWOOL[®]
ADVANCED AIR TREATMENT SOLUTIONS

technical catalogue



MVHR

Effective systems for
healthiness in residential
environment



Via Marconi, 1 – 35020 Legnaro (PD)

Tel. 049.641679

FOR COMMERCIAL INFORMATION

Quote requests:

offerte@teknowoolair.com

Orders:

commerciale@teknowoolair.com

www.teknowoolair.com



RESIDENTIAL MVHR



Mechanical ventilation

The evolution of the comfort concept

QUALITY AIR

Indoor air quality has been one of the most critical issues for our daily lives for years.

We spend most of our time indoors, where the air is much more polluted than outside.

In a 2013 survey, the World Health Organisation assessed people's perception of the time spent indoors compared to the time spent outdoors.

The result was surprising, showing that on average we spend 90% of our time indoors, underestimating and neglecting the impact in terms of health and well-being that poor air quality can have on our body.

The quality of the air we breathe indoors in enclosed spaces is in fact a factor that is very often overlooked and to which greater attention should be paid.

A subsequent survey, conducted in 2018 in Europe and North America, shows that out of 16,000 people interviewed, more than 82% believed they spent at least 3 hours a day outdoors, when in reality they spent more than 22 out of 24 hours in indoor environments. We are not aware that we spend most of our time in enclosed spaces and what repercussions this can have on our health.

The problem of "indoor" pollution is now recognised by many and is more dangerous than outdoor pollution.

When we talk about pollution we generally think of atmospheric pollution, but the truth is that the air inside our homes, offices and other buildings can be 5 to 50 times more polluted than outside. This happens because normal human activities (cooking, cleaning with chemical agents, etc.) and the substances present in all furnishing elements add up to the external pollutants that are trapped and accumulate within the walls of our homes or workplaces.



In the World Health Organization (WHO) report entitled "Ambient Air Pollution: a global assessment of exposure and burden of disease", atmospheric pollution (outdoor and indoor) is recognised as the main environmental risk factor for the health of the world population.

SICK BUILDING SYNDROME

The importance of indoor air quality for people's health has been a known topic since 1987, when the WHO recognised and defined Sick Building Syndrome (SBS) and Multiple Chemical Syndrome (MCS).

The scientific contribution focuses on the consequences that indoor pollution can have on our health, particularly in the environment and workplace. In an in-depth study entitled "Syndromes related to indoor pollution in offices (Building related illnesses – Sick Building Syndrome Idiopathic Environmental Intolerance – multiple chemical syndrome)" it is highlighted how combined exposure to ozone, environmental organic solvents and PM 2.5 (airborne particulate) even at low doses in indoor environments, can constitute a real risk to the physical and psychological integrity of people.

The document shows how in offices an interaction can be created between NOx and VOCs (fat-soluble organic solvents), heavy metals (particulates) and oxidants (ozone) that, synergistically with secondary reactive substances, would determine oxidative stress at the neuronal and immune level.

MAIN SOURCES OF INDOOR POLLUTION

Pollution is invisible: many pollutants are not perceptible and others are even considered healthy or sanitising.

Your home, the environment where your family lives, may not ensure an adequate level of comfort.

Cooking odours, pollen, organic and chemical pollutants are trapped daily in your spaces, irreparably damaging the IAQ (indoor air quality) level of your habitat.

Perceptible pollutants

Odors	cooking and body
Water vapor	contained in the air or from domestic life
Fumes	tobacco or cooking

Pollutants hidden

Allergens	from microorganisms, animals and pollen
Radon	radon (radioactive gas) is naturally present and contained in the ground
Volatile organic compounds (VOC)	found in household cleaning products and building materials
Carbon monoxide	CO is created due to incorrect combustion in heating systems

Mold

Other forms of pollution, also unsightly, are mould and moisture.

Their formation seriously damages the value of your property as well as creating serious hygiene and health problems.

The presence of mould is particularly evident in areas of the home/office where humidity levels are high and where there is poor air circulation, such as north-facing walls, bathroom corners, cellars and basements.

Mould is not only unsightly, it generates bad odours and is an enemy of our health.

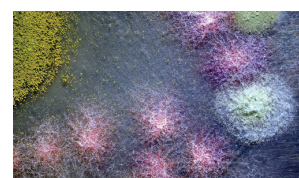

REGULATIONS ON MVHR SYSTEMS

As in all building services sectors, regulations are divided into two groups: **System standards** and **Product standards**.

The **system standards** are used for the sizing and design of ventilation systems: these documents contain the guidelines for correctly sizing a ventilation system for indoor environments, starting from the flow rates considered necessary for adequate air quality in buildings.

The **product standards** are instead used for the correct construction of equipment and components that will form a mechanical ventilation system: these documents are used by equipment manufacturers who must meet the listed requirements. Knowledge of the contents of these standards is also important for designers and energy certifiers.

System standards: UNI 10339 e UNI EN 15251

The standard **UNI 10339:1995** entitled "**Air handling systems for comfort. General information, classification and requirements. Rules for request for quotation, quotation, order and supply**" illustrates the classification of systems, the definition of minimum requirements and the reference values during operation. It applies to air handling systems intended for people's comfort, installed in any case in enclosed buildings, excluding some applications that are contained in specific regulations.

The standard **UNI EN 15251:2008** entitled "**Criteria for the design of the indoor environment and for the evaluation of the energy performance of buildings, in relation to indoor air quality, thermal environment, lighting and acoustics**" specifies the parameters relating to the indoor environment that affect the energy performance of buildings, the methods for defining input parameters relating to the indoor environment for the evaluation of the building as a system and for energy performance calculations, the methods for long-term evaluation of the indoor environment obtained from calculations or measurement results, the parameters to be used and displayed in indoor environments in existing buildings, and how the different categories of criteria relating to the indoor environment can be used, although it does not impose the criteria that must be used.

The standard applies to non-industrial buildings for which indoor environment criteria are defined by human occupancy, where production or process activities do not have a substantial impact on the indoor environment. The standard is applicable to individual dwellings, condominiums, offices, schools, hospitals, hotels and restaurants, sports facilities, wholesale and retail commercial buildings.

For ventilation, Annex "B" establishes the air exchange rate based on the comfort level and number of occupants and/or floor area, using the highest value resulting from the calculation.

Product standards: UNI EN 13141-7, UNI EN 13141-8 and UNI EN 13142

The standard **UNI EN 13141-7:2011** entitled "**Building ventilation – Performance testing of components/products for residential ventilation – Part 7: Performance testing of mechanical supply and exhaust ventilation units (including heat recovery) for mechanical ventilation systems intended for single-family dwellings**" specifies the laboratory test methods and test requirements for determining the aerodynamic, acoustic, thermal performance and electrical consumption of dual-flow mechanical ventilation units (supply and exhaust) used for single-family dwellings.

The standard **UNI EN 13141-8:2014** entitled "**Building ventilation – Performance testing of components/products for residential ventilation – Part 8: Performance testing of non-ducted mechanical supply and exhaust ventilation units (including heat recovery) for mechanical ventilation systems intended for single rooms**" specifies the laboratory test methods and test requirements for verifying the aerodynamic, thermal and acoustic performance, and the electrical power of a non-ducted mechanical supply and exhaust ventilation unit used in a single room.

The purpose of the standard is to test the performance of the equipment.

The standard **UNI EN 13142:2013** entitled "**Ventilation for buildings – Components/products for residential ventilation – Required and optional performance characteristics**" allows the classification of controlled mechanical ventilation systems and specifies the performance characteristics of components/products that may be necessary for the design and sizing of residential ventilation systems to ensure predetermined conditions of temperature comfort, air speed, humidity, hygiene and noise in the occupied zone.

MVHR AND ENERGY LABELLING

From 2016 all ventilation equipment must meet the energy requirements imposed by the EU ErP directive.

The Regulation provides for a classification of units based on intended use:

- The **Residential Ventilation Unit** (RVU) has an airflow rate of up to 250 m³/h or between 250 and 1,000 m³/h but intended exclusively for use in residential buildings as declared by the manufacturer.
- The **Non-Residential Ventilation Unit** (NRVU) has an airflow rate above 250 m³/h or with a flow rate between 250 and 1,000 m³/h if the manufacturer has not declared it is intended exclusively for residential use.

The Regulation also distinguishes ventilation units into two categories based on construction type and therefore use:

- Unidirectional Ventilation Units (UVU)
- Bidirectional Ventilation Units (BVU).

The performance of ventilation units for non-residential applications is defined on the basis of a series of indices. The basic indices are the electrical power absorbed by the fans, fan efficiency and thermal efficiency of the heat recovery unit.

Another very important index is the SEC (Specific Energy Coefficient), i.e. the specific annual energy consumption for ventilating one m² of habitable floor area in a dwelling or building, measured in kWh/(m²a).

The lower the SEC value, the higher the efficiency class of the ventilation unit with heat recovery. The regulation requires as a minimum that recovery units are equipped with multi-speed or variable speed drives.

If speed control systems are used that are also combined with environmental quality probes (for example humidity control probes, CO₂ concentration probes, VOC volatile organic compound sensors, presence sensors, etc.), then there will be a consequent decrease in the SEC value and therefore a higher energy saving class.

Energy efficiency classes of ventilation units

SEC Class	SEC kWh/yr.m ²
A+	SEC < -42
A	-42 ≤ SEC < -34
B	-34 ≤ SEC < -26
C	-26 ≤ SEC < -23
D	-23 ≤ SEC ≤ -20
E	-20 ≤ SEC ≤ -10
F	-10 ≤ SEC ≤ 0
G (minimum efficiency)	0 ≤ SEC

The regulation provides for RVU units maximum noise values produced by non-ducted units intended to be equipped with a connection on the supply or return air side.

LABELS BY UNIT TYPE

Unidirectional Ventilation Units (UVU)

- 1 Name or trademark of the **supplier**
- 2 Identifier of the **model** of the supplier
- 3 **Energy efficiency.** The tip of the arrow containing the energy efficiency class of the appliance is at the height of the tip of the arrow indicating the relevant energy efficiency class; energy efficiency is indicated in relation to average climatic conditions; L337/34 EN Official Journal of the European Union 25.11.2014
- 4 **Sound power level (LWA).** Expressed in dB, rounded to the nearest whole number
- 5 **Maximum air flow rate.** Expressed in m³/h, rounded to the nearest whole number, accompanied by an arrow indicating it is a UVU.

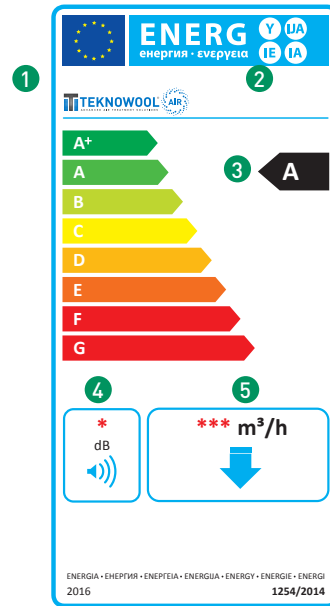

Bidirectional Ventilation Units (BVU)

- 1 Name or trademark of the **supplier**
- 2 Identifier of the **model** of the supplier
- 3 **Energy efficiency.** the tip of the arrow containing the energy efficiency class of the appliance is at the height of the tip of the arrow indicating the relevant energy efficiency class; energy efficiency is indicated in relation to average climatic conditions; L337/34 EN Official Journal of the European Union 25.11.2014
- 4 **Sound power level (LWA).** Expressed in dB, rounded to the nearest whole number
- 5 **Maximum air flow rate.** Expressed in m³/h, rounded to the nearest whole number, accompanied by a double arrow indicating it is a BVU.

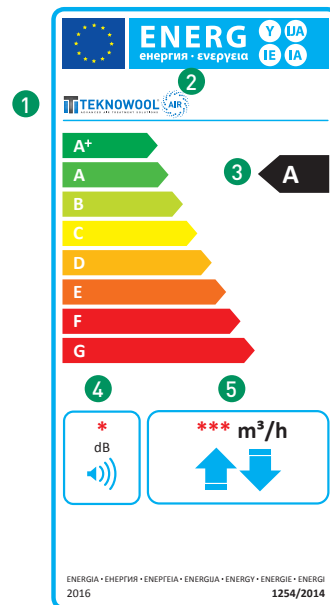

THE SOLUTION: RENEWING THE AIR, WITHOUT WASTING ENERGY

The most effective remedy is certainly represented by **Mechanical Ventilation (MVHR)** with which it is possible to ensure proper air exchange and filtration.

Through the use of these devices, stale air is expelled and at the same time fresh, oxygenated and properly filtered outdoor air is introduced.

The system is developed in a completely non-invasive manner, leaving only the terminal elements visible, and has simple operation with minimal running and maintenance costs.

Indoor comfort is ensured by heating the fresh air, simply by extracting heat from the stale air before it is expelled outside.

All this thanks to a heat exchanger. A high filtration capacity filter prevents the entry of dust, pollen and other particulates suspended in the outdoor air.

TEKNOWOOL AIR offers a range of heat recovery units of different configurations, dimensions and aesthetics, depending on the needs of the environment to be ventilated.

From single- and multi-family homes, new-build or renovation, to simple attic ventilation, wall-mounted, concealed ceiling and floor solutions are available.

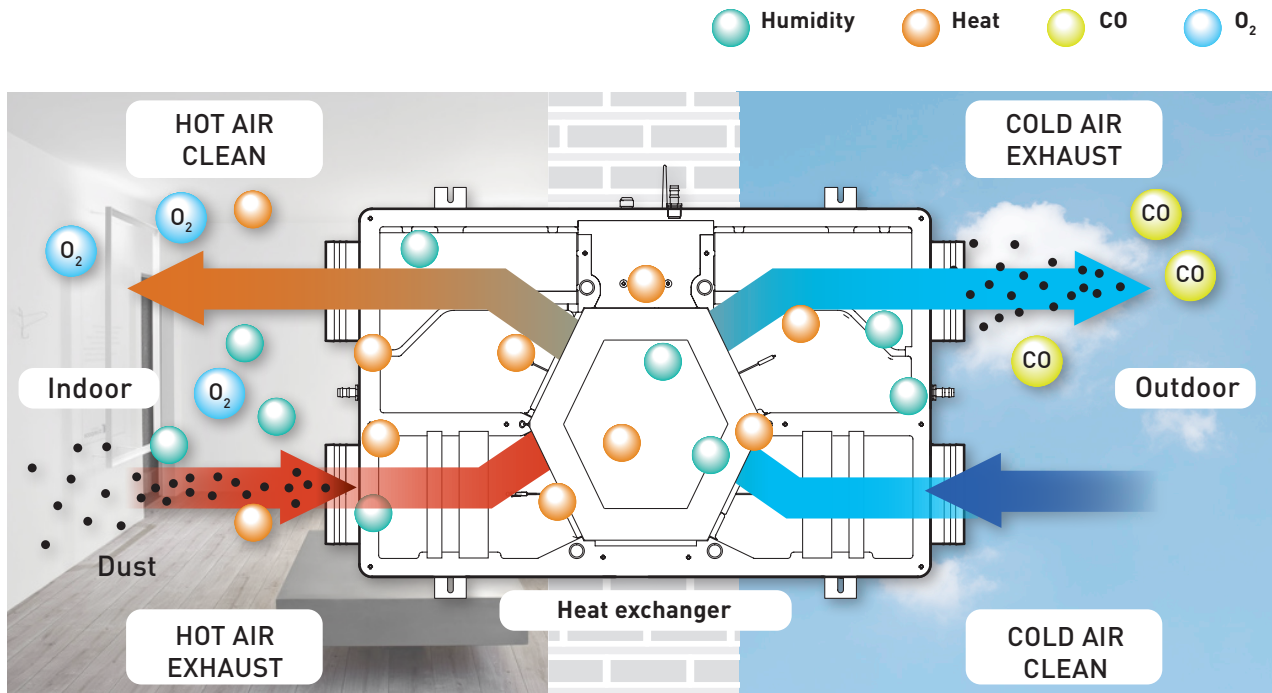

BENEFITS

Quality of life	They renew the room air
	Thanks to the on-board filters, pollutants introduced into the room are kept under control
Energy saving	They pre-heat or pre-cool the fresh air by recovering thermal energy at zero cost that would otherwise be lost (economic and environmental damage)
	Thanks to energy recovery, it is possible to size the HVAC systems more compactly
	They reduce the primary energy requirement of the building (possible class upgrade in building energy certification)
Energy saving	They allow significant reductions in heating/cooling energy costs and enable a reduction in CO emissions ₂ into the atmosphere
	Thanks to tax incentives for interventions that increase the energy efficiency level of buildings

PLUS MVHR



Energy efficiency

The highest levels of energy recovery efficiency (→90%).



Noise control

Equipped with innovative noise control systems

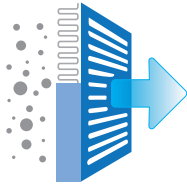

Efficient filtration

Ultra-high efficiency air filtration with ECOFILTRÒ. The units feature a very low consumption electronic system.



Residential use

Heat recovery unit available for residential use.



Integrated dehumidification

Advanced units with integrated dehumidification system.

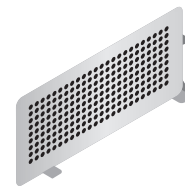

Accessories & design

A wide range of accessories available to provide an efficient and designer air distribution system.

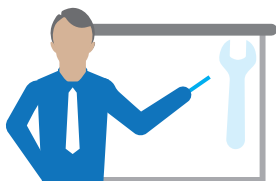

Support and training

Technical support and continuous training for operators and partners.

**SOON
AVAILABLE**



Wi-Fi App

Wi-Fi control and APP for remote system control.

PERFORMANCE CURVES

PERFORMANCE CURVES

Certified EN 13141:7:2011

Available static pressure
Data with standard G4 filters

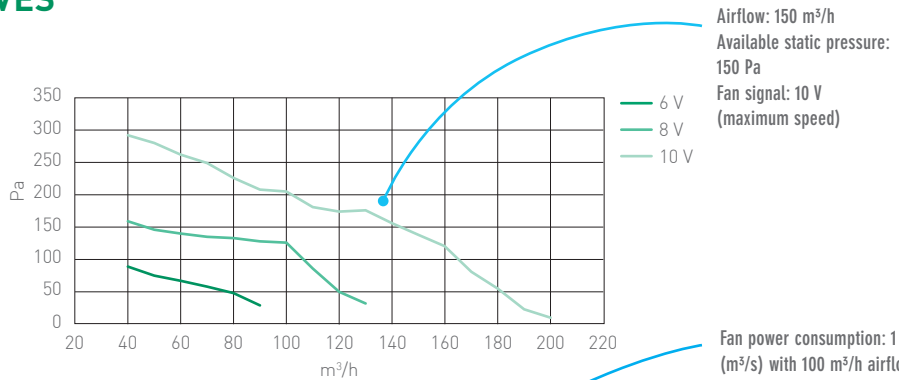

Specific fan power
Data for single fan

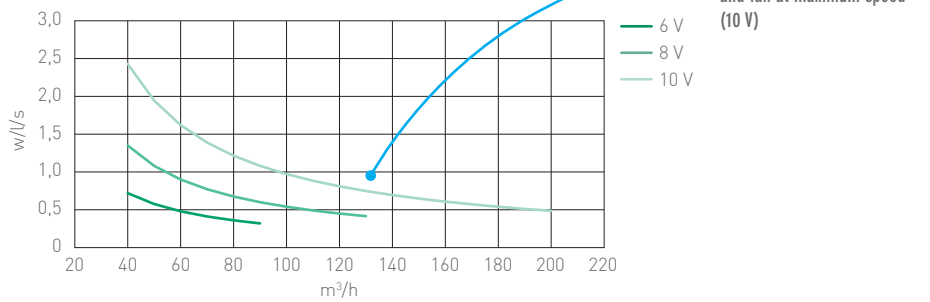

EN 308 CERTIFIED HEAT EXCHANGER

Summer efficiency diagram
Outdoor air: 32 °C / 50% RH
Room air: 26 °C / 50% RH

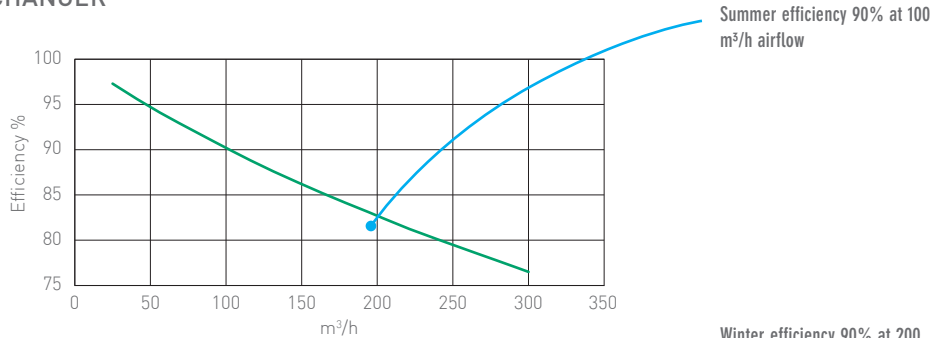

Winter efficiency diagram
Outdoor air: -5 °C / 80% RH
Room air: 20 °C / 50% RH.

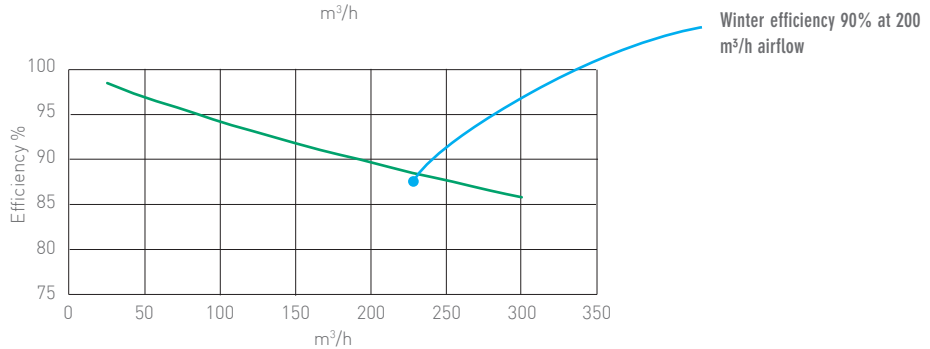

SYMBOLS



Wi-fi regulation



Horizontal installation



Dehumidification



ERP 2018 compliant



Vertical installation



Fan with EC brushless motor



Horizontal and vertical installation



Fan with asynchronous motor

MECHANICAL VENTILATION SYSTEMS

DECENTRALIZED MVHR

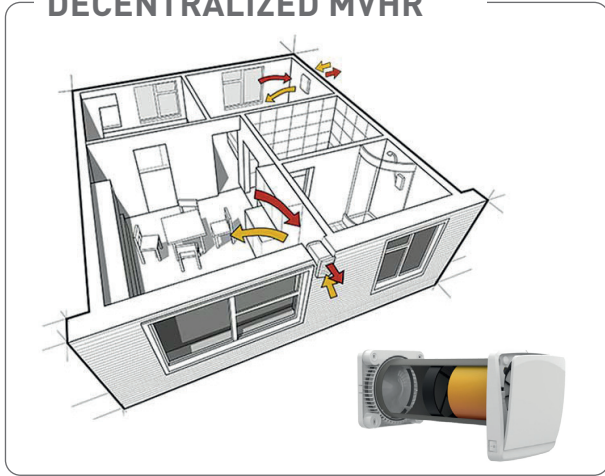

CENTRALIZED MVHR

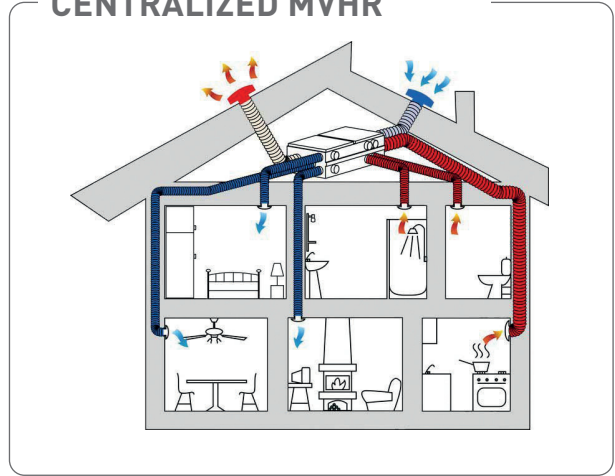

CENTRALIZED INSTALLATION EXAMPLE

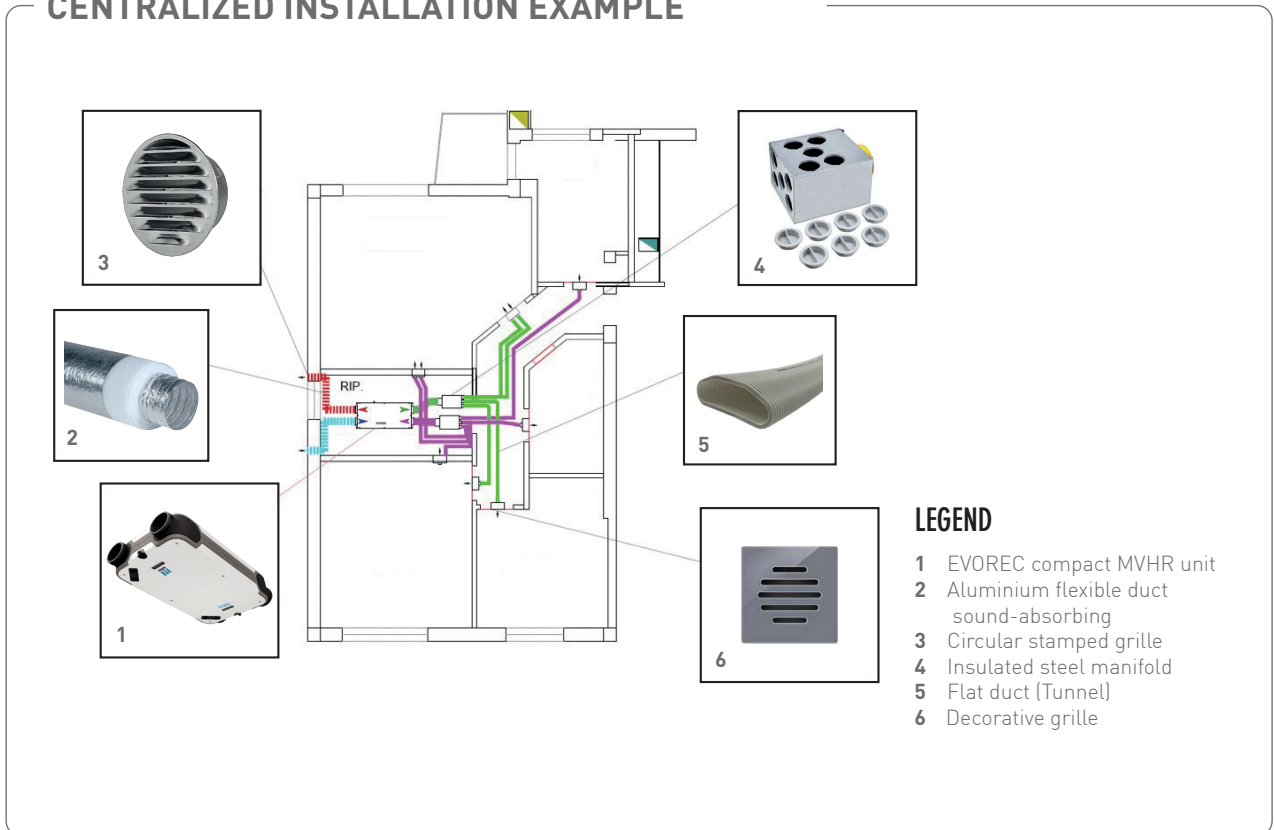

INDEX



MVHR

Maximum air quality
in residential environment



RESIDENTIAL MVHR

Mechanical ventilation

P. 4

Decentralized heat recovery unit

P. 19

RECARM

Decentralized heat recovery unit



P. 18

Centralized heat recovery unit

P. 19

EVOREC

Compact MVHR unit
high performance



P. 20

REC R 220

Complete centralized heat
recovery unit
with controls 220 m³/h



P. 24

REC R 350

Complete centralized heat
recovery unit
with controls 350 m³/h



P. 30

REC R 500

Complete centralized heat
recovery unit
with controls 500 m³/h



P. 36

REC R 800

Complete centralized heat
recovery unit
with controls 800 m³/h



P. 42

Distribution accessories

P. 48

ACCESSORIES

Accessories for
MVHR distribution

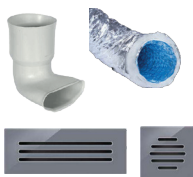

P. 50

Terms of sale

P. 58

HEAT RECOVERY UNIT



MVHR

Maximum air quality
in residential environment



RECARM

Decentralized heat recovery
unit

p. 18



EVOREC

High-performance compact MVHR
unit

p. 20



REC R 220

Centralized heat recovery unit with
controls 220 m³/h

p. 24



REC R 350

Centralized heat recovery unit with
controls 350 mc/h

p. 30



REC R 500

Centralized heat recovery unit with
controls 500 m³/h

p. 36



REC R 800

Centralized heat recovery unit with
controls 800 m³/h

p. 42

RECARM

Decentralized heat recovery unit



Product

RECARM

Functions

Reversible flow heat recovery

Installation

Wall mounted

DESCRIPTION

Decentralized single-room reversible flow heat recovery unit complete with ceramic heat exchanger with efficiency up to 93%. Tilting front panel to prevent unwanted air return when the product is switched off. Extremely quiet. No condensate drain required. Plugs for duct closure during preparation included in the packaging.

MOTOR

DC motor on ball bearings with low consumption and long life. Operating mode adjustable via remote control. Buzzer signal for command reception. The last function set is stored and restored automatically in case of power interruption.

FILTERS

Separate double G3 class filters for inlet and outlet air. Variable-length duct from 250 to 500 mm. Maximum applicable length 3 m (2.5 m with 90° bend). Visual indicators for command reception and filter cleaning.

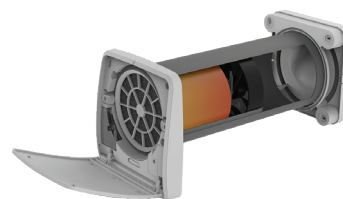

TECHNICAL SPECIFICATIONS

Parameter description	Unit of measurement	Values
Power supply	Volt/Hz	220-240 / 50
Speed	N.	1 - 2 - 3
Power consumption	W	9
Air flow rate (in and out)	m ³ /h	60
Noise level	dB(A)	23
Protection degree		IPX4
Ceramic heat exchanger efficiency	%	up to 93
Duct section diameter	mm	Ø 160
Filters included	N.	2
Filtration class	EN 779	G3
Maximum pressure	mm H ₂ O/Pa	3,7/36





MVHR

Maximum air quality
in residential environment

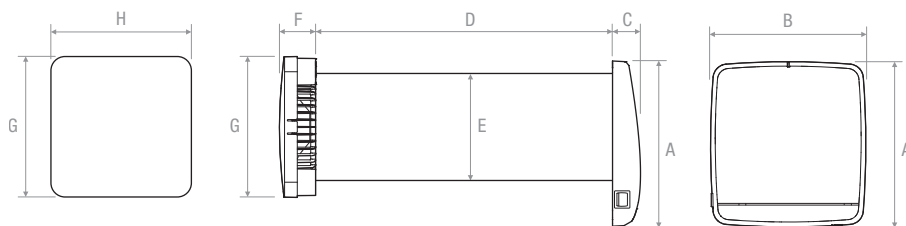

A	B	C	D	ØE	F	G	H
mm	mm	mm	mm	mm	mm	mm	mm
250	233	40	500	160	48	212	212

Weight: 5 kg

ISO COARSE 45% Optional Kit

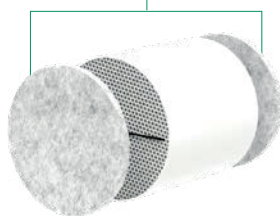

- 42 mc/h
- 28 mc/h
- 12 mc/h
- 5 mc/h

STANDARD

Included Kit

- 50 m³/h
- 32 m³/h
- 15 m³/h
- 7 m³/h

The ISO COARSE 45% filter, compared to the standard dust filter, allows more efficient filtration of particles with Ø greater than 10 µm (such as hair, pollen, sand, dust in general).

AIR SPEED

- 3 Levels
- 60 m³/h
- 45 m³/h
- 30 m³/h



HUMIDITY CONTROL

MODE

- Automatic
- Monitoring
- Manual



NIGHT FUNCTION

Night mode: allows minimizing flow rate and noise during the night.



FLOW REGULATION

Allows you to choose the speed level also in combination with airflow, outlet and inlet functions.



BOOST FUNCTION

Allows air extraction at maximum speed for a specific period of time.



FILTER FUNCTION

When the maintenance control light is on, the unit does not stop but continues to operate until the reset operation.

EVOREC

High-performance compact MVHR unit



DESCRIPTION

EVOREC is a high-efficiency heat recovery unit with EC electronic fans.

Ensures constant airflow, acoustic comfort, reduced consumption, ease of maintenance and optimal air quality. Included: 4-button wireless remote control with LED filter clog indicator.

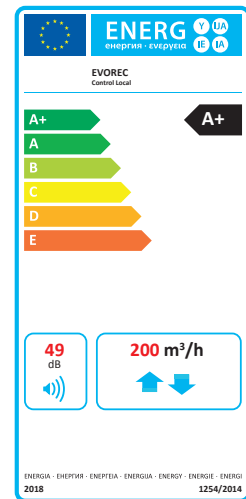

Reduced height: 21 cm
Air flow rate: up to 200 m³/h.

CONSTRUCTION ADVANTAGES

- ✓ Passivhaus Certificate
- ✓ 99% recyclable
- ✓ Energy class A+
- ✓ Heat exchange core efficiency →95%
- ✓ High acoustic comfort
- ✓ Constant airflow technology
- ✓ Automatic bypass
- ✓ Control via wireless connection

INSTALLATION ADVANTAGES

- ✓ Vertical or horizontal installation
- ✓ Easily convertible to mirrored version
- ✓ Quick installation
- ✓ Adjustable connections
- ✓ Double condensate drain
- ✓ Orientation guides on both sides

SUSTAINABILITY



ZERO CARBON FOOTPRINT

Reduction of greenhouse gas emissions, a fundamental step in managing the impact of climate change.

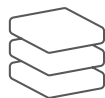

99.9% RECYCLABLE

Construction in expanded polypropylene and galvanized steel, which can be recycled, reducing resource consumption and environmental degradation.

DIMENSIONI E DIAGRAMMA FLUSSI D'ARIA

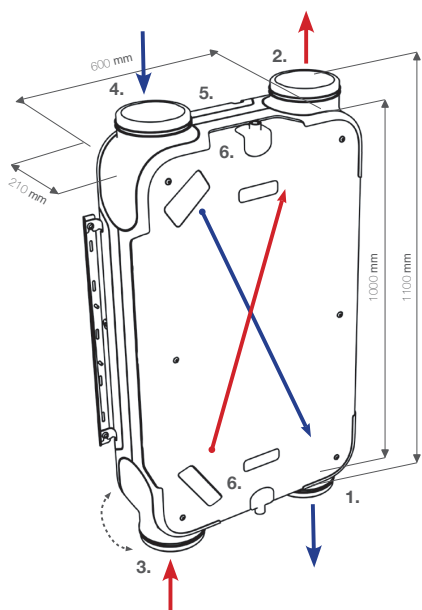

RIGHT CONFIGURATION

LEGEND

- 1. Indoor air supply
- 2. Stale air exhaust
- 3. Indoor air intake
- 4. Fresh air supply
- 5. Electrical connections
- 6. Condensate drain



Smart control accessories

Smart remote control - 4 adjustment levels

Ball condensate drain

CO sensor₂ wireless

Wireless humidity sensor

Smart Home accessories

EVO App: allows smart control of the unit and excellent air quality



Height of only 21 cm
Optimizes space in the false ceiling

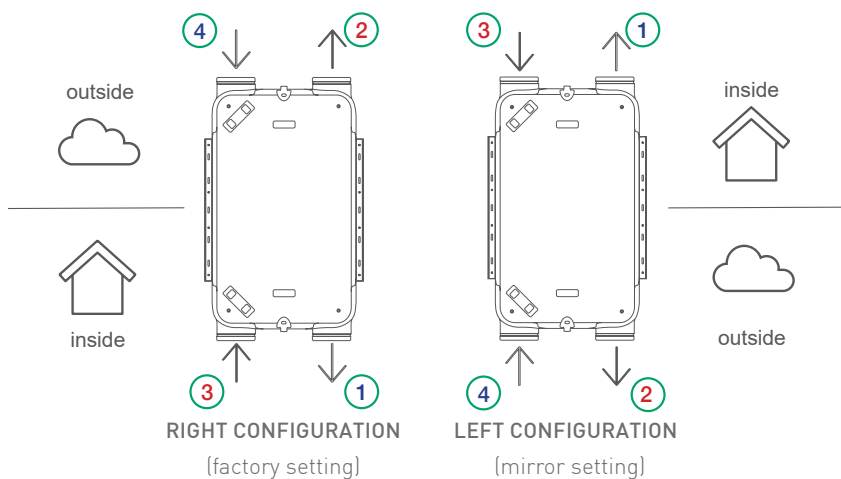

LEGEND

- 1 Indoor air supply
- 2 Stale air exhaust
- 3 Indoor air intake
- 4 Supply and fresh air

MAKE YOUR HOME SMART



KNX
Modbus



Take care of your health and your family's, check the air quality of your home!

Thanks to the smart control, you get a complete online service for managing EVO functions.

TECHNICAL DATA

EVOREC					
Supply voltage	230V / 1ph / 50Hz				
Protection degree	IP40				
Dimensions (w x h x d)	1000 x 600 x 210 mm				
Connection diameter	Ø 160				
Condensate drain diameter	1/2"				
Weight	24Kg				
Filter classification	COARSE 65% (G4)				
Fan setting (factory settings)					"BOOST" MODE
Smart wireless control (optional)	0	1	2	3	max
Air flow rate (m³/h)	30	75	100	150	200

EVOREC ACOUSTIC PERFORMANCE								
		Air flow rate (m³/h)	75	125	150	200		
Sound level Lw (A)	Static pressure (Pa)		20	50	50	100	150	200
	Casing radiation (dB(A))		33	42	44	46	51	56
	Extract duct (dB(A))		34	43	45	48	50	57
	Supply duct (dB(A))		46	51	59	62	65	66

CHARACTERISTIC CURVE

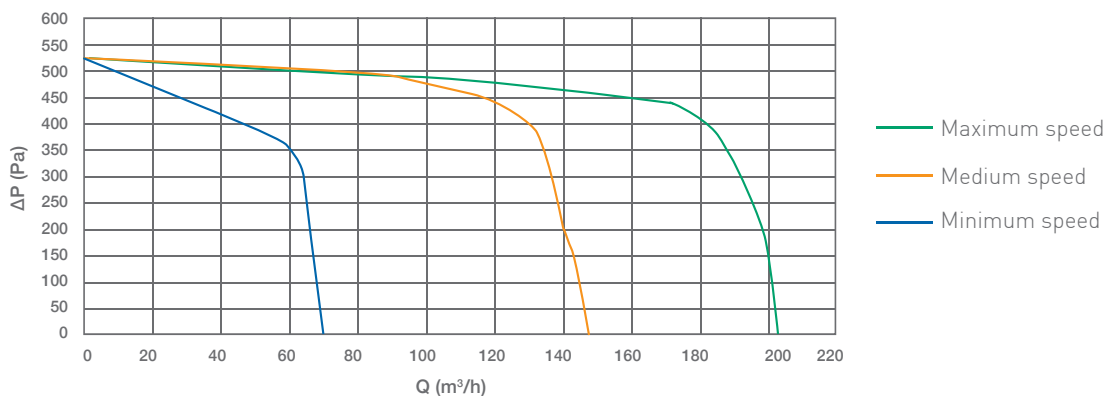





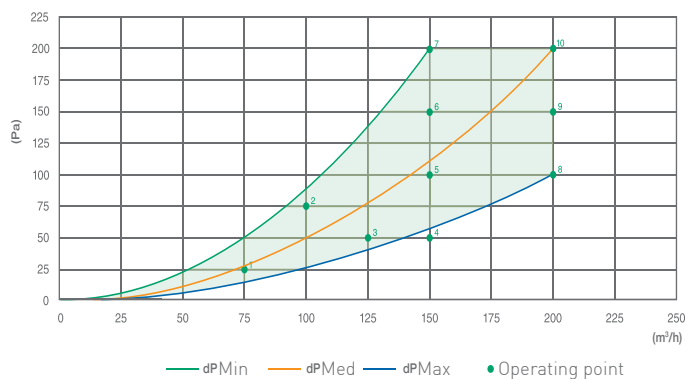



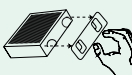
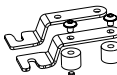

Control smart wireless (optional)	Air flow rate (m³/h)	Pressure (Pa)	Power (W)	SFP (W/L/S)
1	75	25	12.61	0.61
2	100	75	25.31	0.91
3	125	50	29.16	0.84
4	150	50	39.20	0.94
5	150	100	49.65	1.19
6	150	150	60.92	1.46
7	150	200	72.60	1.74
8	200	100	81.33	1.46
9	200	150	93.10	1.68
10	200	200	106.48	1.92

AIR FLOW RATE / PRESSURE



TECHNICAL DATA

	DESCRIPTION	IMAGE
Heat exchanger cross-flow	High-efficiency plastic heat exchanger	
Fans EC Brushless	Constant flow ventilation technology, EC brushless centrifugal fan with inclined blades forward. This technology ensures acoustic comfort, low electrical consumption, and easy maintenance.	
High-efficiency filters (optional)	Offers the widest range of filters on the market, to ensure optimal air quality. DFFG4 - G4 FILTER COARSE 65% (2 filters included) DFFF7 - F7 FILTER EPM 1 55% DFFG4F7 - COMBINED FILTER G4 + F7 COARSE 65% - EPM 1 55% DFFCA - ACTIVATED CARBON FILTER DFFF9 - F9 FILTER EPM 1 80% DFFG4F9 - COMBINED FILTER G4 + F9 COARSE 65% - EPM 1 80% DFFCAG4 - ACTIVATED CARBON FILTER + G4	
Easy maintenance	Easy access to filter cleaning, directly from the front panel. Simple access and removal of heat exchanger and fans (recommended every 3 years)	
Easy installation and fast	Installation possible on both ceiling and wall, with the possibility of fixing the guides on all sides of the unit thanks to the versatility of the silentblock hooks. Normal or mirrored position configuration of the unit by reversing the duct connection directions on both sides.	
Construction high performance	The internal watertight construction in expanded polypropylene (EPP), and the external construction in powder-coated galvanised steel RAL 9003, ensure acoustic insulation, thermal insulation and air tightness. 99% recyclable material, reducing the planet's resource consumption.	
Adjustable connections	Modularity in quick and easy connection. The air connections are designed to ensure maximum sealing. Double symmetrical gasket ensuring duct sealing when coupled with the unit.	
Low consumption	High-performance EC motors ensuring the lowest energy consumption.	
Wireless control	<ul style="list-style-type: none"> Smart wireless multi-control remote with electronic regulation and dirty filter indicator. 4-position wireless push-button panel with LED filter clogging indicator. 	
Smart bypass	The 100% automatic by-pass is used to take advantage of any favourable temperature conditions inside the home without passing through the heat exchanger. This management is automatic (factory setting).	
Home automation gateway (Optional accessory)	KNX - Modbus connectivity. Make your home smart.	
APP (Optional accessory)	Intelligent online control system of the most important elements for monitoring of indoor air quality at home.	
Airflows (right and left version)	Possibility to configure the unit in 2 versions. Right version (factory settings) and by activating the "mirror mode" the left version is simply configured.	

REC R 220

Centralized heat recovery unit with controls 220 m³/h



Vertical



Horizontal

DESCRIPTION

Centralized heat recovery unit with plug-and-play wireless controls and integrated bypass. Self-supporting structure in pre-painted sheet metal, thermal/acoustic insulation in 22 mm rock wool.

HEAT EXCHANGE CORE

Counter-flow heat exchange core, in polypropylene, with efficiency >90% in optimal ambient conditions.

FANS

EC fans, backward-curved centrifugal, low consumption.

Product

REC R 220 H/V

Installation

Horizontal/Vertical

Efficiency ratings

> 90%

FILTERS

F7 (ePM1 70%) filters with low pressure drop, for both extract and fresh air.

TECHNICAL SPECIFICATIONS

Parameter description	Unit of measurement	Values
Air flow rate	mc/h	269
Available static pressure	Pa	100
Thermal efficiency	%	>90
Nominal voltage	V	230 – 1F
Frequency	Hz	50-60
Consumption at maximum flow rate	A	1.5
Nominal power	W	173
Filters	Class	F7 (ePM1 70%)

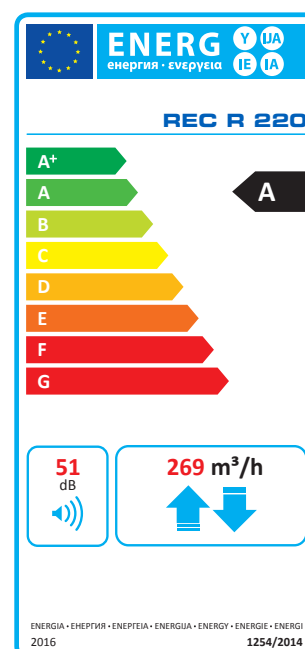



MVHR

Maximum air quality
in residential environment

DIMENSIONS

Horizontal version (H)

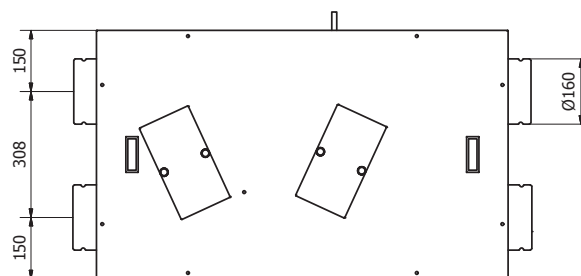
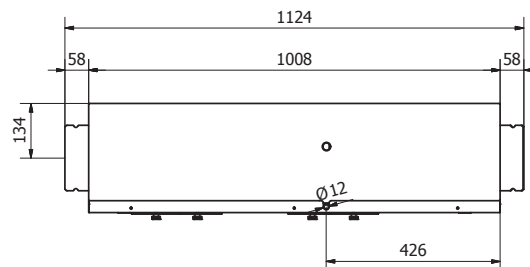
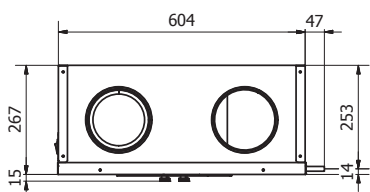
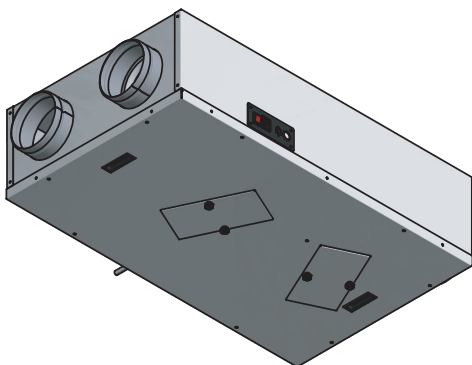

CONFIGURATIONS

Nominal duct diameter: Ø 160 mm Weight: 42 kg
Sound pressure level at 1.5 m (L_{pA} in dB(A)): 39 dB(A)

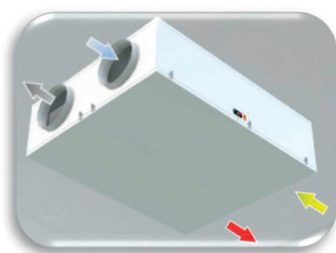

HS (standard)
CEILING

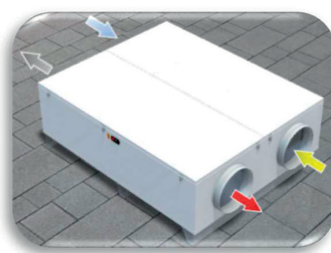

HB
BASE

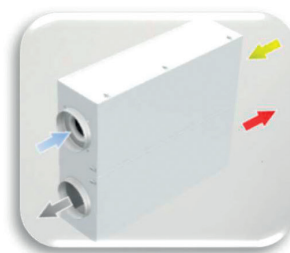

HP
WALL

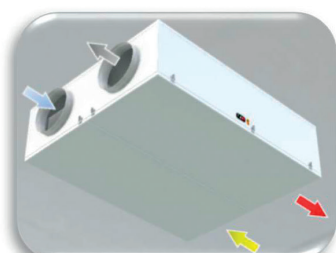

KS*
CEILING

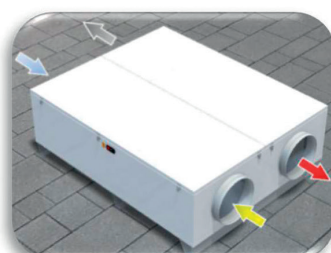

KB*
BASE

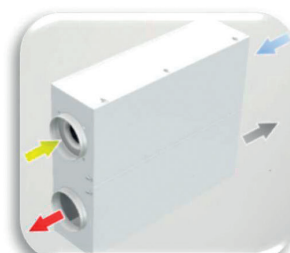

KP*
WALL

LIGHT BLUE	RENEWAL (outdoor air intake)	YELLOW	RETURN (extraction from the room)
GREY	EXHAUST (exhaust to outside)	RED	SUPPLY (room supply)

DIMENSIONS

Vertical version (V)

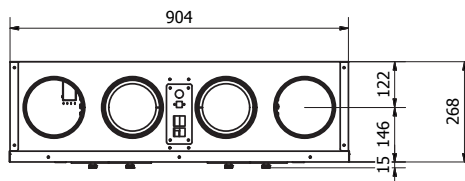
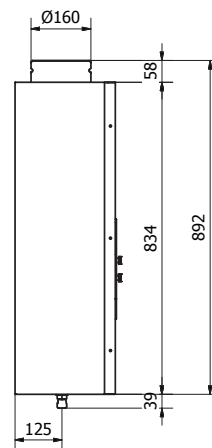
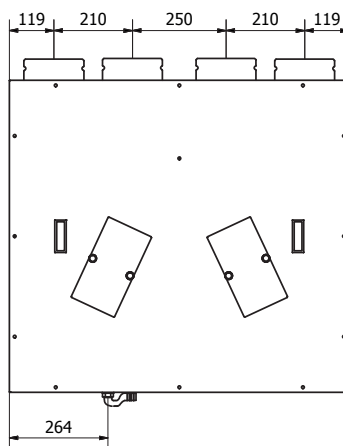
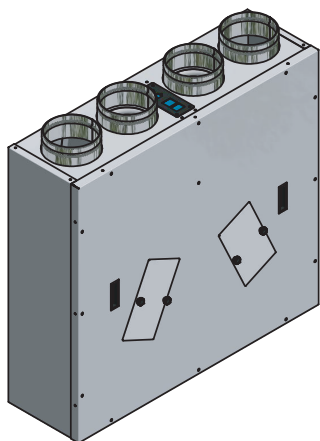

CONFIGURATIONS

Nominal duct diameter: Ø 160 mm Weight: 53 kg
 Sound pressure level at 1.5m (L_{pa} in dB(A)): 39 dB(A)

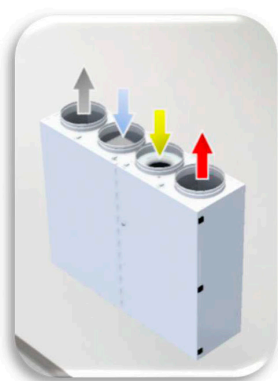

VA (standard)
WALL



VB*
WALL

LIGHT BLUE	RENEWAL (outdoor air intake)	YELLOW	RETURN (extraction from the room)
GREY	EXHAUST (exhaust to outside)	RED	SUPPLY (room supply)



MVHR

Maximum air quality
in residential environment

AERAUIC PERFORMANCE

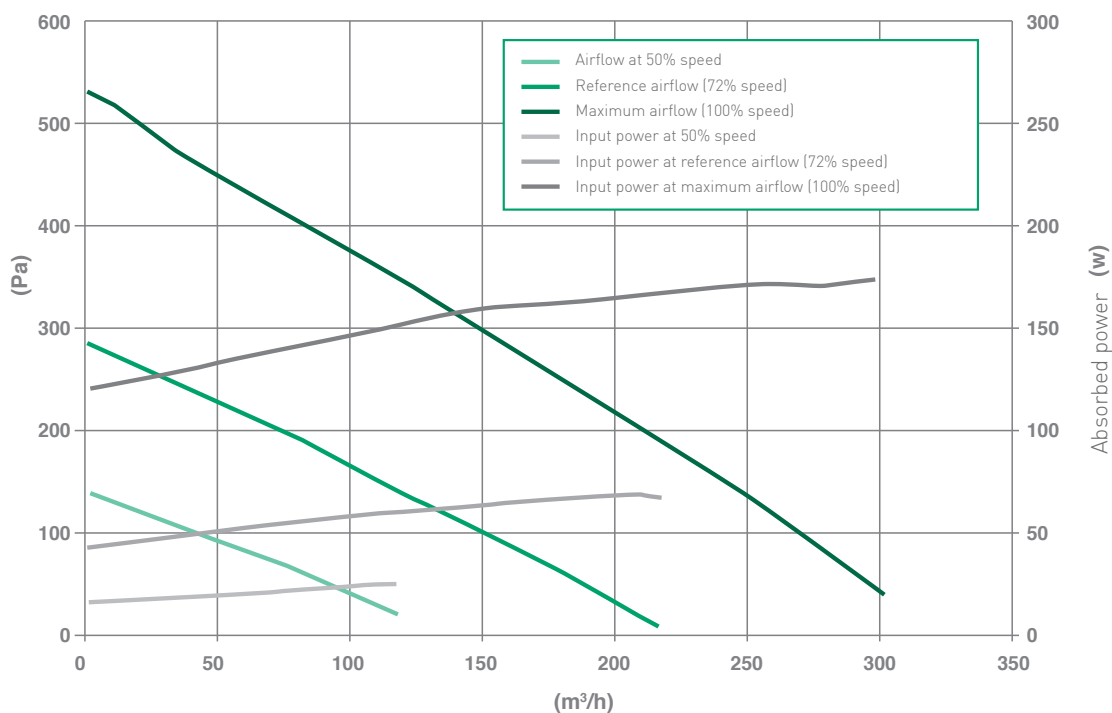

HEAT RECOVERY UNIT THERMAL EFFICIENCY

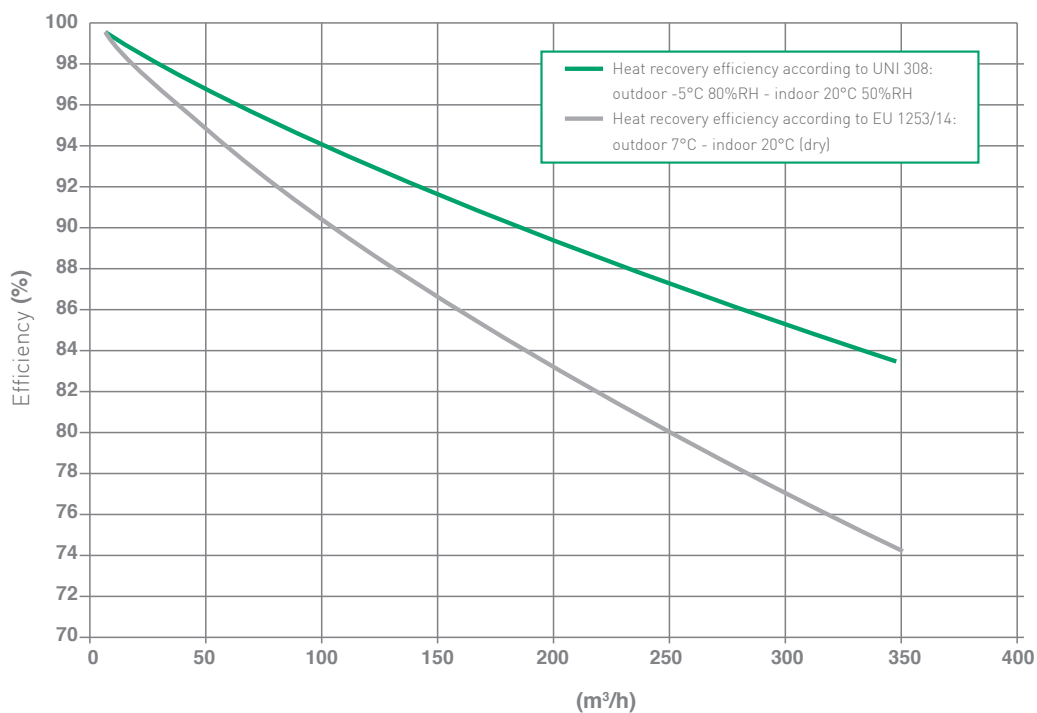

CONTROL TYPES

Electronic control board with numerous functions, including:

- speed selection 1, 2, 3 or automatic
- constant flow/pressure management option (optional)
- automatic bypass management for free-cooling and free-heating
- frost protection (also with electric heater),
- filter alarm with hour counter (optional with pressure switch)
- management of humidity, temperature, air quality, CO sensors₂...
- control of water coils and electric heaters for pre-treatment and/or post-treatment.
- ModBus communication.

Available in the following versions:

- SE on-board electronic card;
- EB white LCD display, with integrated humidity and room temperature sensors
SE+EB are included in the heat recovery unit supply
- ET colour touch-screen display (on request)

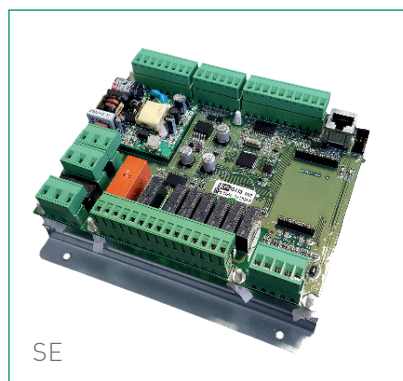

SE



EB



ET

**MVHR**Maximum air quality
in residential environment**PRODUCT DATA SHEET**

Model identifier		REC R 220 H/V EB
Specific energy consumption in kWh/(m ² .a) per zone climate and SEC class	Cold climate Mild climate Hot climate	-73,7 kWh/m ² .a -36,4 kWh/m ² .a -12,4 kWh/m ² .a
Energy class		A
Product type		BVU, bidirectional
Motor type		Variable speed
Heat recovery system		Counter-flow heat exchanger
Heat recovery thermal efficiency*		83,9%
Maximum air flow rate (m ³ /h)*		269 m ³ /h
Electrical power consumption at maximum flow rate (W)*		173 W
Sound power level (L _{wa} in dB(A))		51 dB(A)
Reference air flow rate (m ³ /s)*		0,052 m ³ /s
Pressure difference (Pa)*		50 Pa
Specific power consumption (W/(m ³ /h))		0,35 W/(m ³ /h)
Control type		Centralized environmental control
Control coefficient		0,85
Leakage rate (%)	indoor outdoor recirculation	1,4% 2,2% Not applicable
Mixing rate (%)		Not applicable
Position and description of visual signal filter warning		Alarm displayed on remote display
Fresh air supply installation		Not applicable
Air flow sensitivity to variations pressure at + 20Pa and - 20Pa (%)		Not applicable
Internal / external air tightness (m ³ /h)		Not applicable
Annual electricity consumption (AEC) specific for a 100m ² dwelling (kWh of electricity /yr)**	Cold climate Mild climate Hot climate	895,4 kWh elettr./a 358,4 kWh elettr./a 313,4 kWh elettr./a
Annual heating saving specific for a 100m ² dwelling (kWh of primary energy /yr)**	Cold climate Mild climate Hot climate	8733,8 kWh en.prim./a 4464,5 kWh en.prim./a 2018,8 kWh en.prim./a

* as per regulation no. 1253/2014

** calculated as per regulation no. 1254/2014

*3 humidity, CO sensor, air quality, presence sensor...

REC R 350

Centralized heat recovery unit with controls 350 m³/h



Vertical



Horizontal

DESCRIPTION

Centralized heat recovery unit with plug-and-play wireless controls and integrated bypass. Self-supporting structure in pre-painted sheet metal, thermal/acoustic insulation in 22 mm rock wool.

HEAT RECOVERY UNIT

Counter-flow heat recovery unit, in polypropylene, with efficiency >90%.

FANS

EC fans, backward-curved centrifugal, low consumption.

Product	REC R 350 H/V
Installation	Horizontal/Vertical
Efficiency ratings	> 90%

FILTERS

F7 (ePM1 70%) filters with low pressure drop, for both extract and fresh air

TECHNICAL SPECIFICATIONS

Parameter description	Unit of measurement	Values
Air flow rate	mc/h	352
Available static pressure	Pa	100
Thermal efficiency	%	>90
Nominal voltage	V	230 – 1F
Frequency	Hz	50-60
Consumption at maximum flow rate	A	1.5
Nominal power	W	175
Filters	Class	F7 (ePM1 70%)

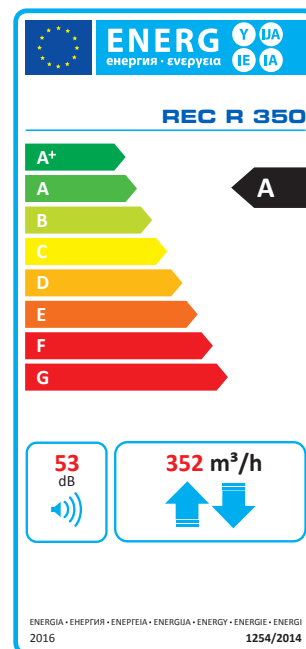



MVHR

Maximum air quality
in residential environment

DIMENSIONS

Horizontal version (H)

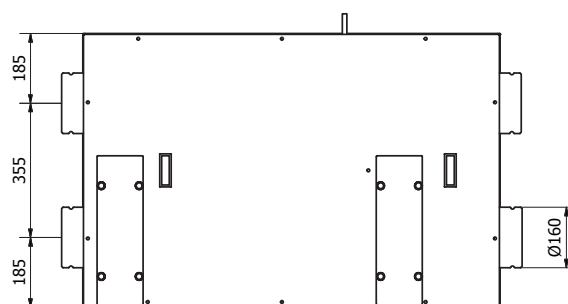
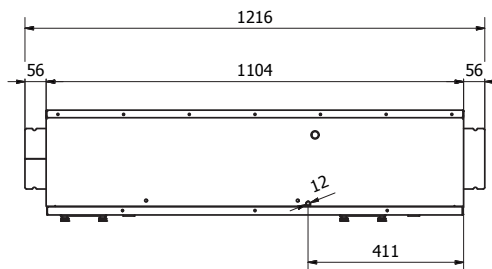
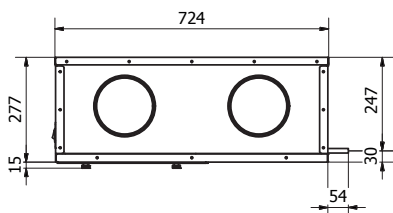
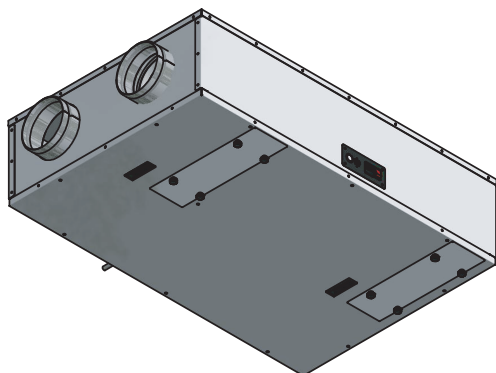

CONFIGURATIONS

Nominal duct diameter: Ø 160 mm Weight: 46 kg
Sound pressure level at 1.5 m (Lpa in dB(A)): 42 dB(A)

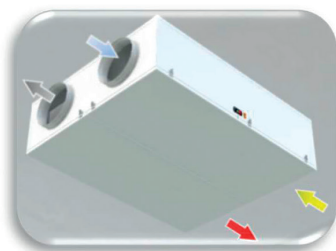

HS (standard)
CEILING

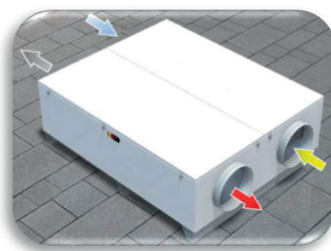

HB*
BASE

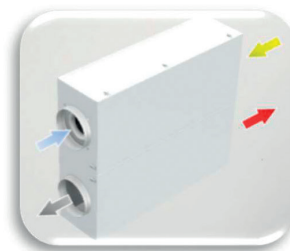

HP*
WALL

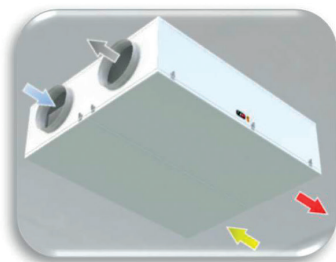

KS*
CEILING

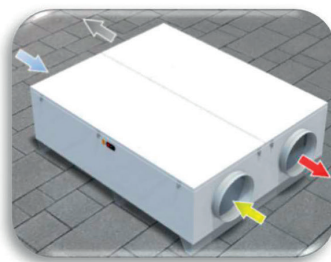

KB*
BASE

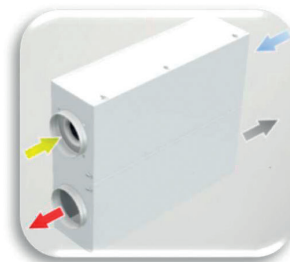

KP*
WALL

LIGHT BLUE	RENEWAL (outdoor air intake)	YELLOW	RETURN (extraction from the room)
GREY	EXHAUST (exhaust to outside)	RED	SUPPLY (room supply)

DIMENSIONS

Vertical version (V)

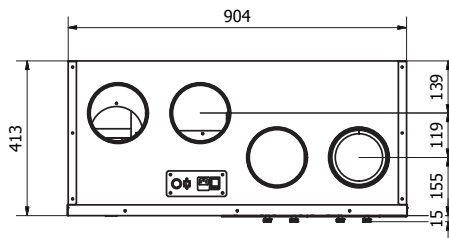
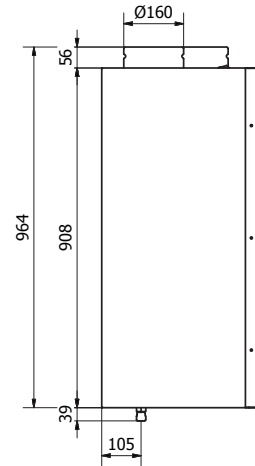
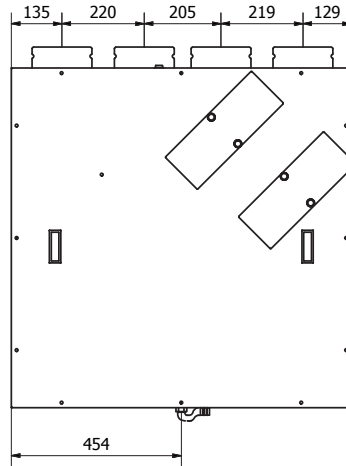
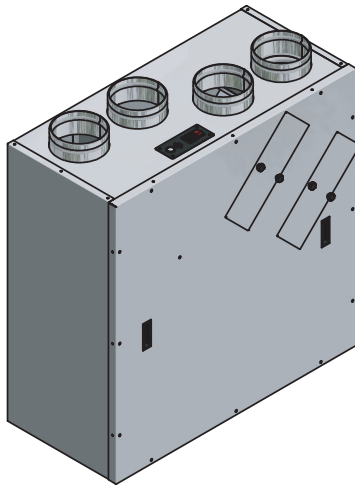

CONFIGURATIONS

Nominal duct diameter: Ø 160 mm Weight: 75 kg
 Sound pressure level at 1.5m (L_{pa} in dB(A)): 42 dB(A)



VC (standard)
WALL



VD*
WALL

LIGHT BLUE	RENEWAL (outdoor air intake)	YELLOW	RETURN (extraction from the room)
GREY	EXHAUST (exhaust to outside)	RED	SUPPLY (room supply)



MVHR

Maximum air quality
in residential environment

AERAILIC PERFORMANCE

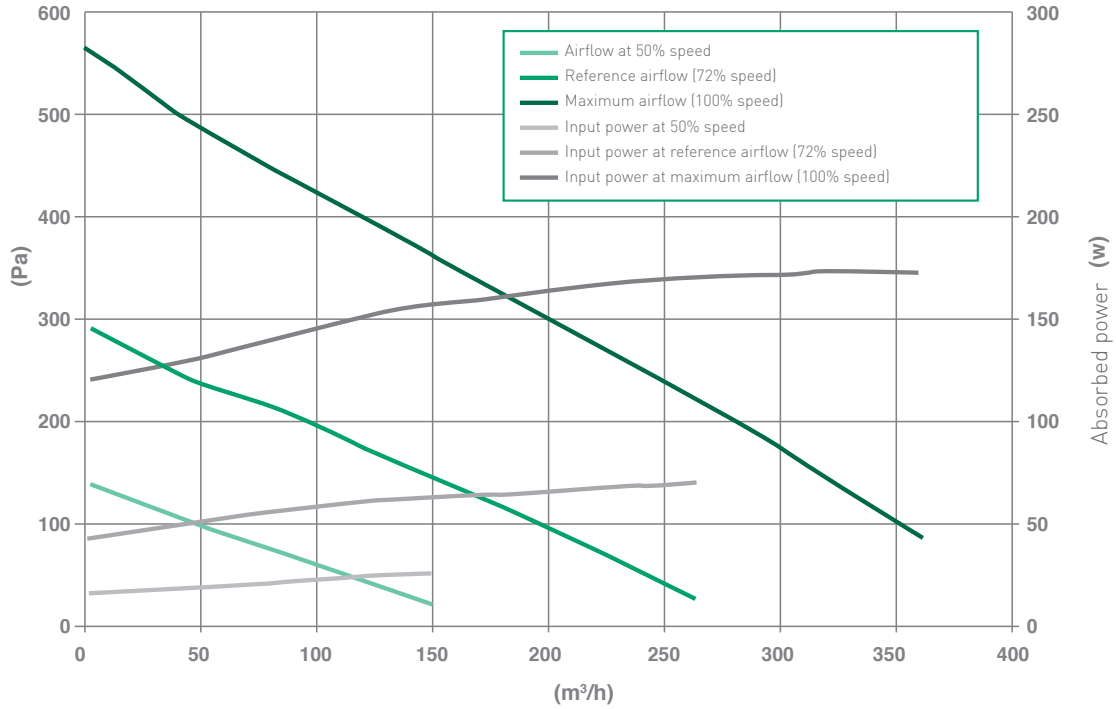

HEAT RECOVERY UNIT THERMAL EFFICIENCY

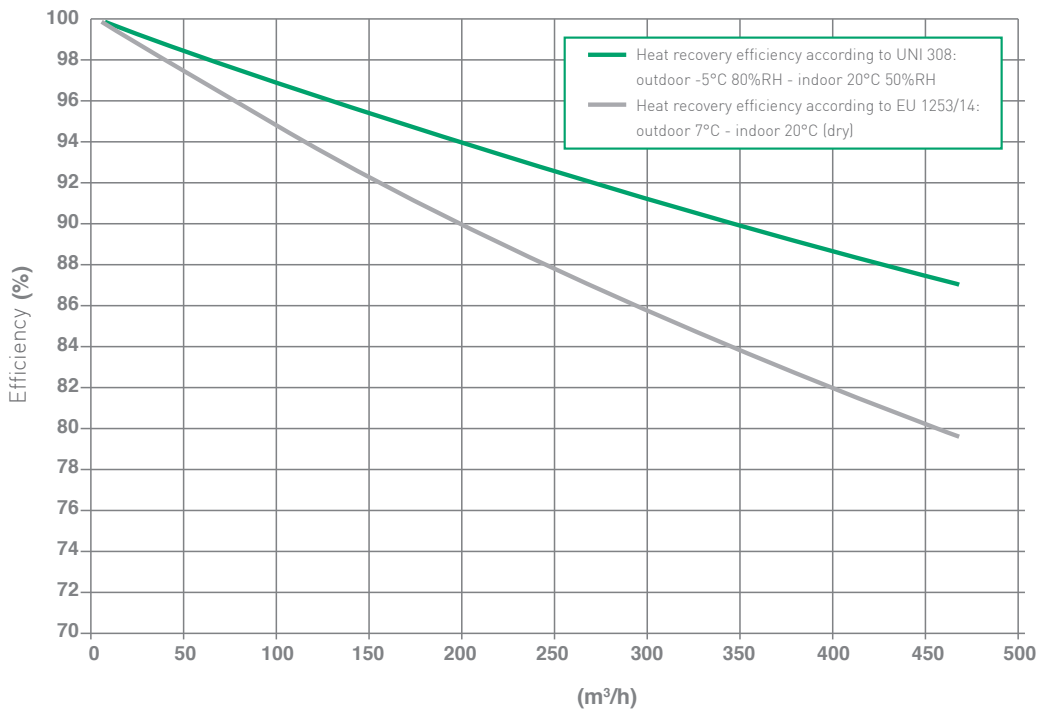

CONTROL TYPES

Electronic control board with numerous functions, including:

- speed selection 1, 2, 3 or automatic
- constant flow/pressure management option (optional)
- automatic bypass management for free-cooling and free-heating
- frost protection (also with electric heater),
- filter alarm with hour counter (optional with pressure switch)
- management of humidity, temperature, air quality, CO sensors₂...
- control of water coils and electric heaters for pre-treatment and/or post-treatment.
- ModBus communication.

Available in the following versions:

- SE on-board electronic card;
- EB white LCD display, with integrated humidity and room temperature sensors
SE+EB are included in the heat recovery unit supply
- ET colour touch-screen display (on request)

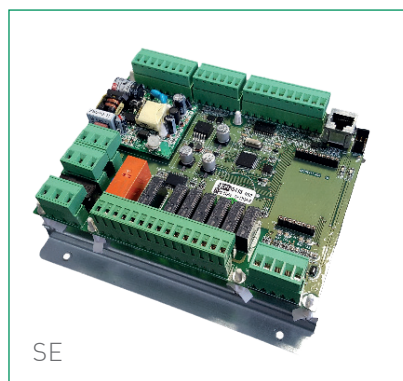

SE



EB



ET

**MVHR**Maximum air quality
in residential environment**PRODUCT DATA SHEET**

Model identifier		REC R 350 H EB	REC R 350 V EB
Specific energy consumption in kWh/(m ² .a) per zone climate and SEC class	Cold climate Mild climate Hot climate	-77,2 kWh/m ² .a -38,9 kWh/m ² .a -14,3 kWh/m ² .a	-78,4 kWh/m ² .a -39,8 kWh/m ² .a -15,1 kWh/m ² .a
Energy class		A	A
Product type		BVU, bidirectional	BVU, bidirectional
Motor type		Variable speed	Variable speed
Heat recovery system		Counter-flow heat exchanger	Counter-flow heat exchanger
Heat recovery thermal efficiency*		87,9%	88,7%
Maximum air flow rate (m ³ /h)*		352 m ³ /h	394 m ³ /h
Electrical power consumption at maximum flow rate (W)*		175 W	176 W
Sound power level (L _{wa} in dB(A))		53 dB(A)	54 dB(A)
Reference air flow rate (m ³ /s)*		0,068 m ³ /s	0,077 m ³ /s
Pressure difference (Pa)*		50 Pa	50 Pa
Specific power consumption (W/(m ³ /h))		0,28 W/(m ³ /h)	0,25 W/(m ³ /h)
Control type		Centralized environmental control	Centralized environmental control
Control coefficient		0,85	0,85
Leakage rate (%)	indoor outdoor recirculation	1,1% 1,9% Not applicable	1,2% 2,1% Not applicable
Mixing rate (%)		Not applicable	Not applicable
Position and description of visual signal filter warning		Displayed alarm on the remote display	Displayed alarm on the remote display
Fresh air supply installation		Not applicable	Not applicable
Air flow sensitivity to variations pressure at + 20Pa and - 20Pa (%)		Not applicable	Not applicable
Internal / external air tightness (m ³ /h)		Not applicable	Not applicable
Annual electricity consumption (AEC) specific for a 100m ² dwelling (kWh of electricity /yr)**	Cold climate Mild climate Hot climate	838,4 kWh elettr./a 301,4 kWh elettr./a 256,4 kWh elettr./a	809,7 kWh elettr./a 272,7 kWh elettr./a 277,7 kWh elettr./a
Annual heating saving specific for a 100m ² dwelling (kWh of primary energy /yr)**	Cold climate Mild climate Hot climate	8945,7 kWh en.prim./a 4572,8 kWh en.prim./a 2067,8 kWh en.prim./a	8988,0 kWh en.prim./a 4594,5 kWh en.prim./a 2077,6 kWh en.prim./a

* as per regulation no. 1253/2014

** calculated as per regulation no. 1254/2014

* 3 humidity, CO sensor, air quality, presence sensor...

REC R 500

Centralized heat recovery unit with controls 500 m³/h



Vertical



Horizontal

DESCRIPTION

Centralized heat recovery unit with plug-and-play wireless controls and integrated bypass. Self-supporting structure in pre-painted sheet metal, thermal/acoustic insulation in 22 mm rock wool.

HEAT RECOVERY UNIT

Counter-flow heat recovery unit, in polypropylene, with efficiency >90%.

FANS

EC fans, backward-curved centrifugal, low consumption.

Product

REC R 500 H/V

Installation

Horizontal/Vertical

Efficiency ratings

> 90%

FILTERS

F7 (ePM1 70%) filters with low pressure drop, for both extract and fresh air

TECHNICAL SPECIFICATIONS

Parameter description	Unit of measurement	Values
Air flow rate	mc/h	510
Available static pressure	Pa	100
Thermal efficiency	%	>90
Nominal voltage	V	230 – 1F
Frequency	Hz	50-60
Consumption at maximum flow rate	A	2.7
Nominal power	W	332
Filters	Class	F7 (ePM1 70%)

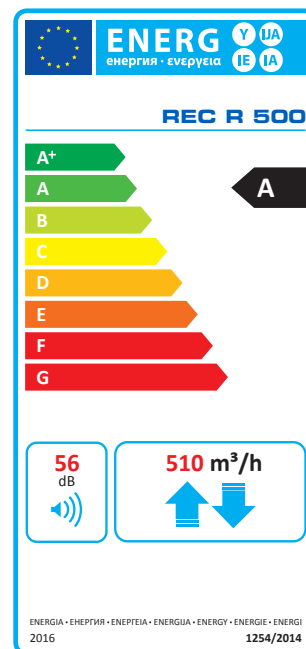



MVHR

Maximum air quality
in residential environment

DIMENSIONS

Horizontal version (H)

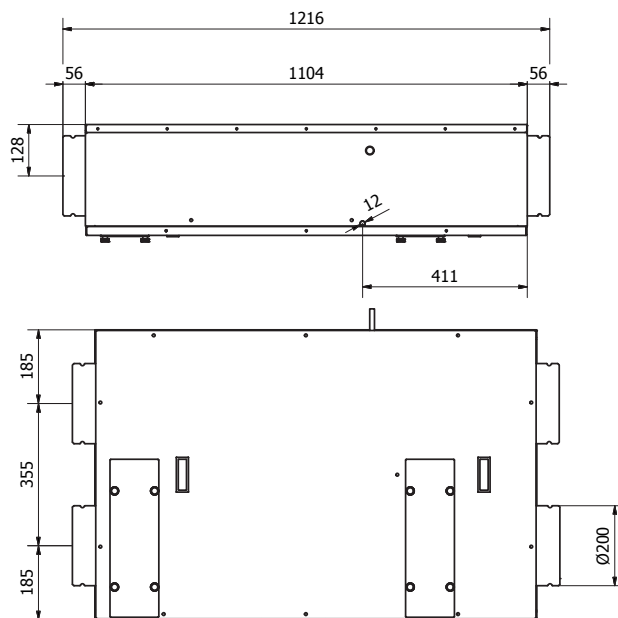
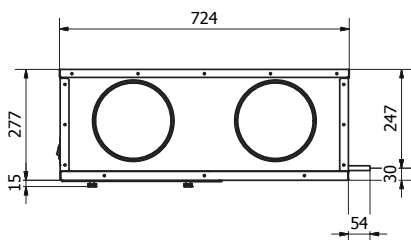
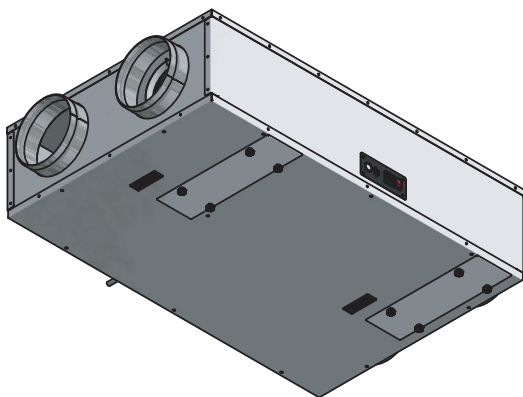

CONFIGURATIONS

Nominal duct diameter: Ø 200 mm Weight: 49 kg
Sound pressure level at 1.5 m (Lpa in dB(A)): 44 dB(A)

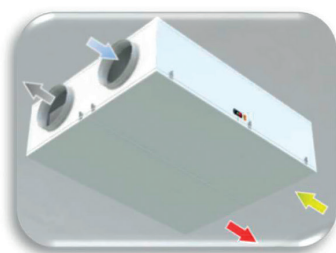

HS (standard)
CEILING

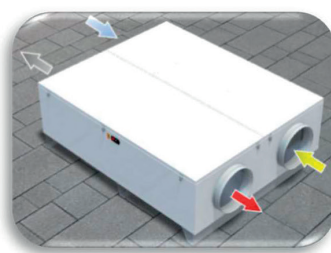

HB*
BASE

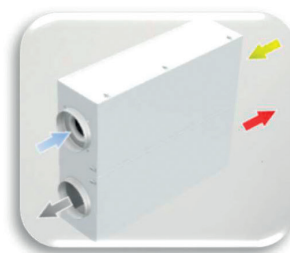

HP*
WALL

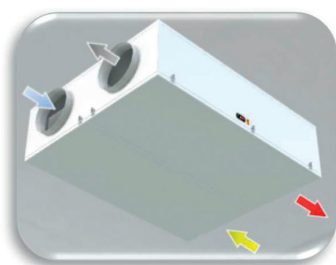

KS*
CEILING

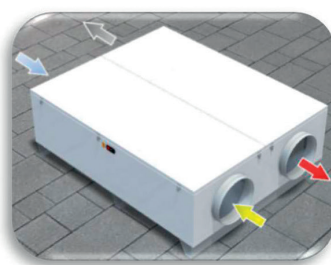

KB*
BASE

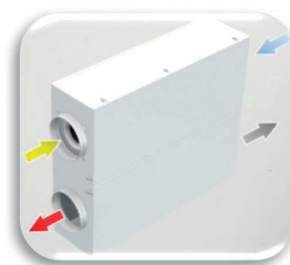

KP*
WALL

LIGHT BLUE	RENEWAL (outdoor air intake)	YELLOW	RETURN (extraction from the room)
GREY	EXHAUST (exhaust to outside)	RED	SUPPLY (room supply)

DIMENSIONS

Vertical version (V)

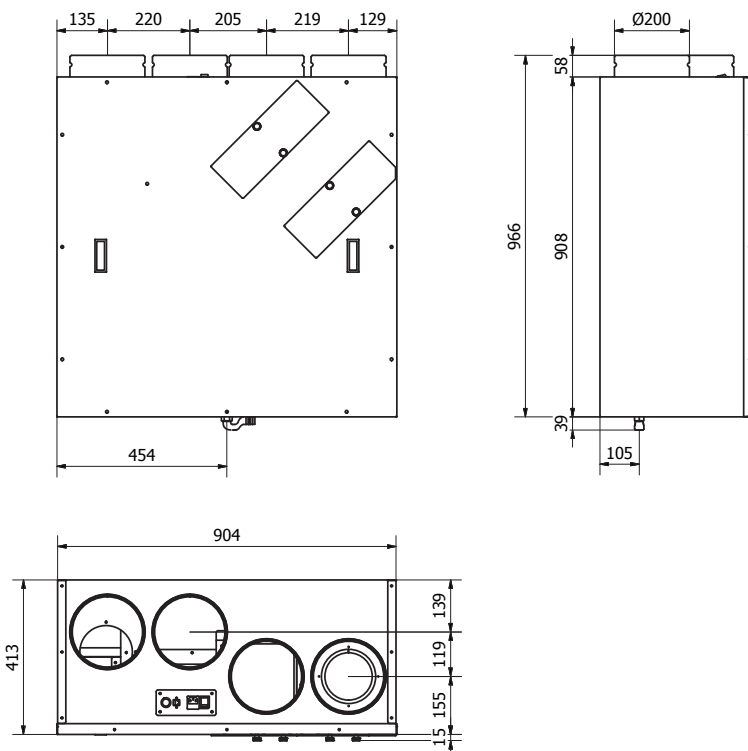
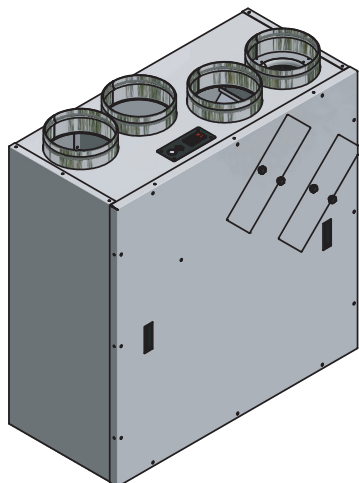

CONFIGURATIONS

Nominal duct diameter: Ø 200 mm Weight: 77 kg
 Sound pressure level at 1.5m (L_{pa} in dB(A)): 44 dB(A)

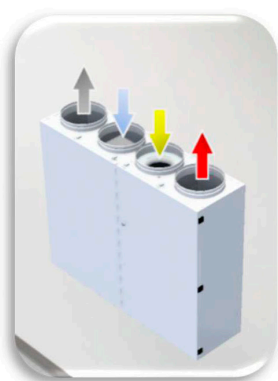

VC (standard)
WALL



VD*
WALL

LIGHT BLUE	RENEWAL (outdoor air intake)	YELLOW	RETURN (extraction from the room)
GREY	EXHAUST (exhaust to outside)	RED	SUPPLY (room supply)



MVHR

Maximum air quality
in residential environment

AERAUIC PERFORMANCE

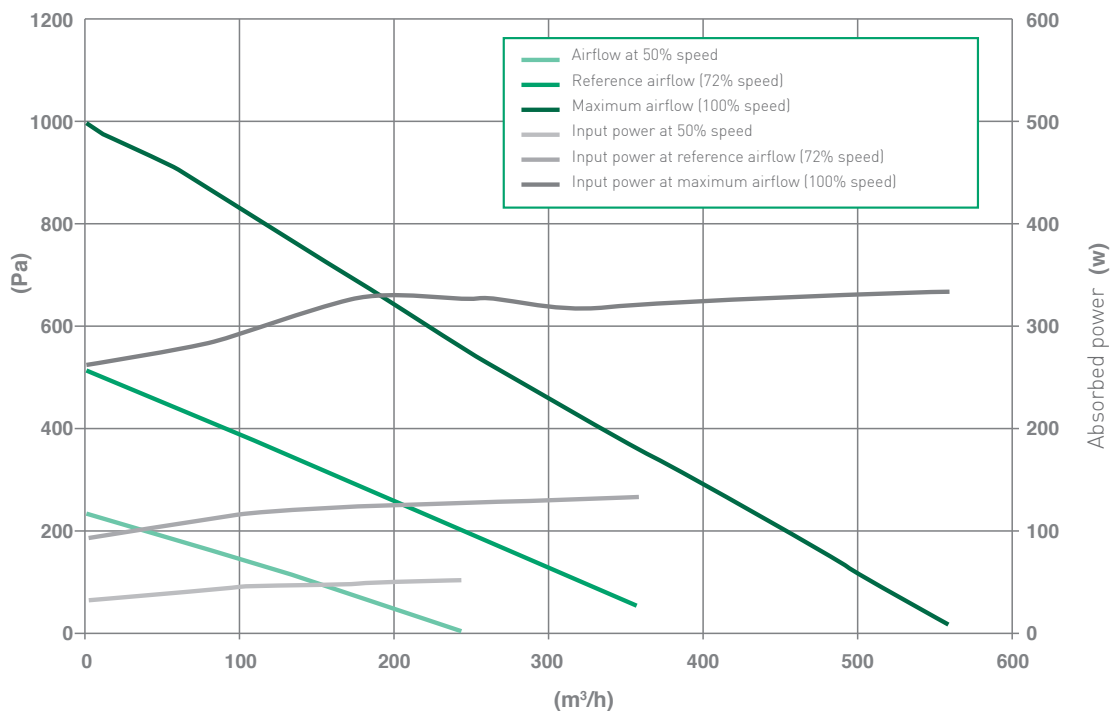

HEAT RECOVERY UNIT THERMAL EFFICIENCY

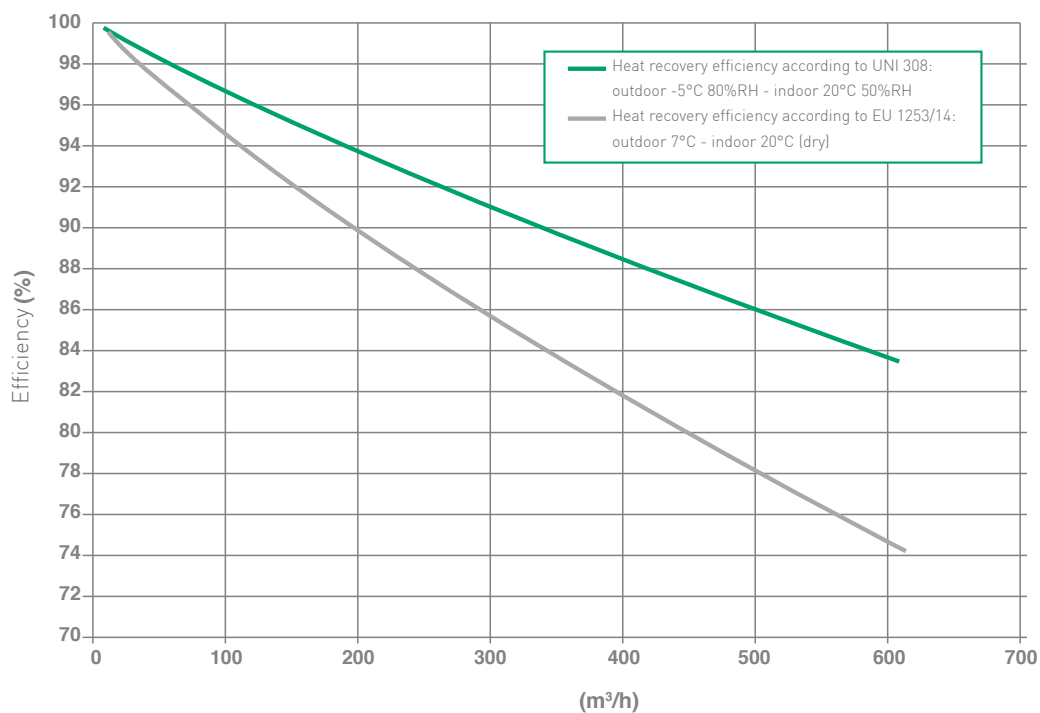

CONTROL TYPES

Electronic control board with numerous functions, including:

- speed selection 1, 2, 3 or automatic
- constant flow/pressure management option (optional)
- automatic bypass management for free-cooling and free-heating
- frost protection (also with electric heater),
- filter alarm with hour counter (optional with pressure switch)
- management of humidity, temperature, air quality, CO sensors₂...
- control of water coils and electric heaters for pre-treatment and/or post-treatment.
- ModBus communication.

Available in the following versions:

- SE on-board electronic card;
- EB white LCD display, with integrated humidity and room temperature sensors
SE+EB are included in the heat recovery unit supply
- ET colour touch-screen display (on request)

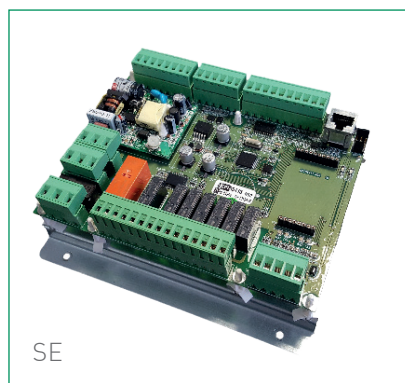

SE



EB



ET

**MVHR**Maximum air quality
in residential environment**PRODUCT DATA SHEET**

Model identifier		REC R 500 H EB	REC R 500 V EB
Specific energy consumption in kWh/(m ² .a) per zone climate and SEC class	Cold climate Mild climate Hot climate	-72,9 kWh/m ² .a -35,7 kWh/m ² .a -11,7 kWh/m ² .a	-74,5 kWh/m ² .a -37,0 kWh/m ² .a -12,8 kWh/m ² .a
Energy class		A	A
Product type		BVU, bidirectional	BVU, bidirectional
Motor type		Variable speed	Variable speed
Heat recovery system		Counter-flow heat exchanger	Counter-flow heat exchanger
Heat recovery thermal efficiency*		83,4%	84,7%
Maximum air flow rate (m ³ /h)*		510 m ³ /h	568 m ³ /h
Electrical power consumption at maximum flow rate (W)*		332 W	334 W
Sound power level (L _{wa} in dB(A))		56 dB(A)	56 dB(A)
Reference air flow rate (m ³ /s)*		0,099 m ³ /s	0,110 m ³ /s
Pressure difference (Pa)*		50 Pa	50 Pa
Specific power consumption (W/(m ³ /h))		0,37 W/(m ³ /h)	0,33 W/(m ³ /h)
Control type		Centralized environmental control	Centralized environmental control
Control coefficient		0,85	0,85
Leakage rate (%)	indoor outdoor recirculation	0,9% 1,7% Not applicable	1,0% 1,8% Not applicable
Mixing rate (%)		Not applicable	Not applicable
Position and description of visual signal filter warning		Displayed alarm on the remote display	Displayed alarm on the remote display
Fresh air supply installation		Not applicable	Not applicable
Air flow sensitivity to variations pressure at + 20Pa and - 20Pa (%)		Not applicable	Not applicable
Internal / external air tightness (m ³ /h)		Not applicable	Not applicable
Annual electricity consumption (AEC) specific for a 100m ² dwelling (kWh of electricity /yr)**	Cold climate Mild climate Hot climate	917,2 kWh elettr./a 380,2 kWh elettr./a 335,2 kWh elettr./a	880,2 kWh elettr./a 343,2 kWh elettr./a 298,2 kWh elettr./a
Annual heating saving specific for a 100m ² dwelling (kWh of primary energy /yr)**	Cold climate Mild climate Hot climate	8707,3 kWh en.prim./a 4451,0 kWh en.prim./a 2012,7 kWh en.prim./a	8776,2 kWh en.prim./a 4486,2 kWh en.prim./a 2028,6 kWh en.prim./a

* as per regulation no. 1253/2014

** calculated as per regulation no. 1254/2014

* 3 humidity, CO sensor, air quality, presence sensor...

REC R 800

Centralized heat recovery unit with controls 800 m³/h



Vertical



Horizontal

Product	REC R 800 H/V
Installation	Horizontal/Vertical
Efficiency ratings	> 90%

DESCRIPTION

Centralized heat recovery unit with plug-and-play wireless controls and integrated bypass. Self-supporting structure in pre-painted sheet metal, thermal/acoustic insulation in 22 mm rock wool.

HEAT RECOVERY UNIT

Counter-flow heat recovery unit, in polypropylene, with efficiency >90%.

FANS

EC fans, backward-curved centrifugal, low consumption.

FILTERS

F7 (ePM1 70%) filters with low pressure drop, for both extract and fresh air

TECHNICAL SPECIFICATIONS

Parameter description	Unit of measurement	Values
Air flow rate	mc/h	900
Available static pressure	Pa	55 (V) / 85 (H)
Thermal efficiency	%	>90
Nominal voltage	V	230 – 1F
Frequency	Hz	50-60
Consumption at maximum flow rate	A	2.9
Nominal power	W	380
Filters	Class	F7 (ePM1 70%) SUPPLY M5(ePM10 50%) EXTRACT



MVHR

Maximum air quality
in residential environment

DIMENSIONS

Horizontal version (H)

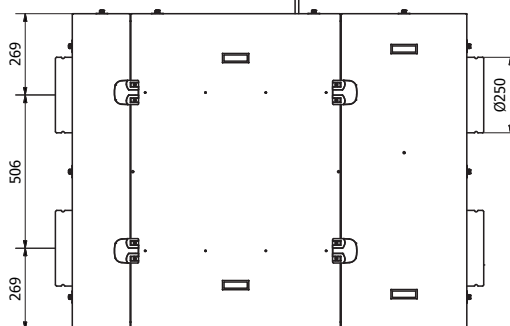
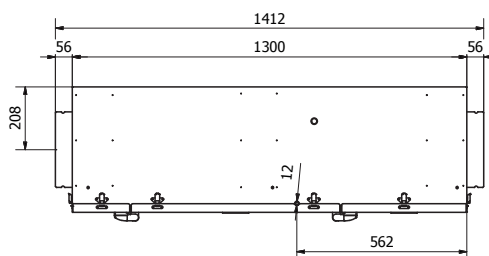
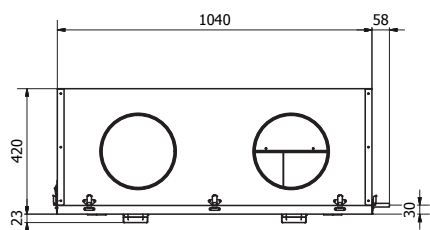
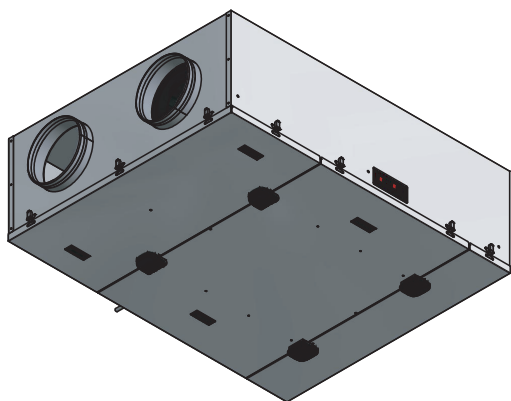

CONFIGURATIONS

Nominal duct diameter: Ø 250 mm Weight: 100 kg
Sound pressure level at 1.5 m (Lpa in dB(A)): 47 dB(A)

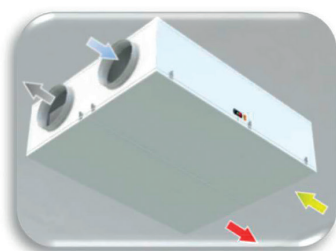

HS (standard)
CEILING

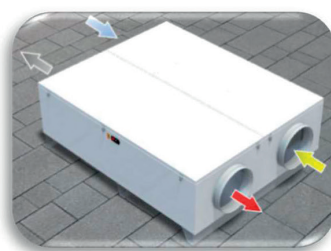

HB*
BASE

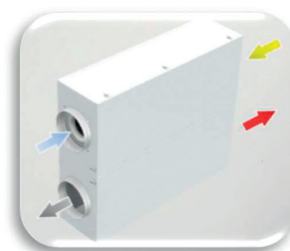

HP*
WALL

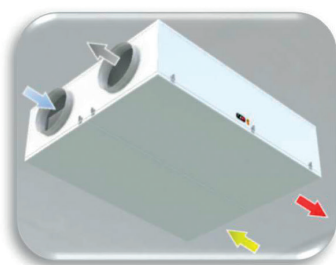

KS*
CEILING

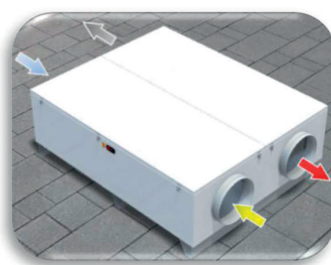

KB*
BASE

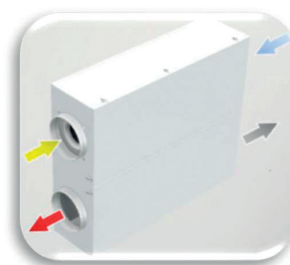

KP*
WALL

LIGHT BLUE	RENEWAL (outdoor air intake)	YELLOW	RETURN (extraction from the room)
GREY	EXHAUST (exhaust to outside)	RED	SUPPLY (room supply)

DIMENSIONS

Vertical version (V)

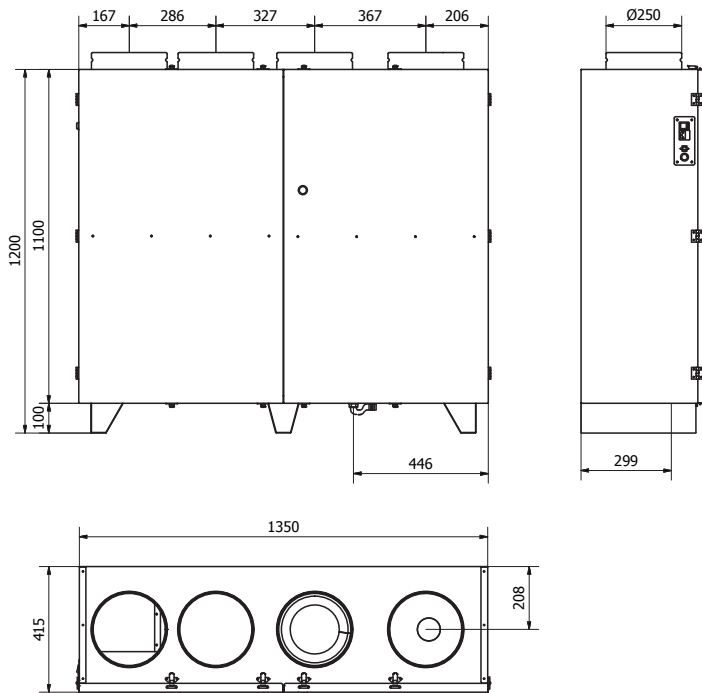
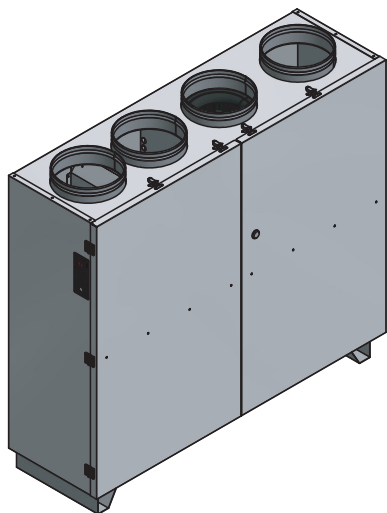

CONFIGURATIONS

Nominal duct diameter: $\varnothing 250$ mm Weight: 95 kg
 Sound pressure level at 1.5m (L_{pa} in dB(A)): 47 dB(A)

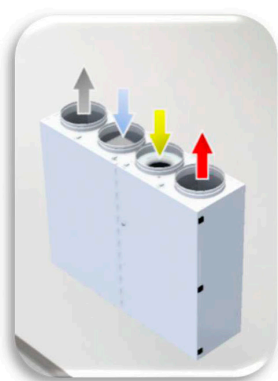

UA (standard)
WALL



UB*
WALL

LIGHT BLUE	RENEWAL (outdoor air intake)	YELLOW	RETURN (extraction from the room)
GREY	EXHAUST (exhaust to outside)	RED	SUPPLY (room supply)



MVHR

Maximum air quality
in residential environment

AERAILIC PERFORMANCE

	Air flow rate nominal (m ³ /h)	Air flow rate nominal q _{nom} (m ³ /s)	Efficiency fan η _{s,Fan} (%)	Efficiency heat exchanger η _{L_nvu} (%)	Sound power L _{wa} (dB(A))	Internal specific power SFP _{int} (W(m ² /s))	Nominal external pressure Δp _{s,ext} (Pa)
1	900	0,250	52,8	80,1	57	1154,5	85
1_b	950	0,264	51,1	79,3	58	1257,6	37
2	298	0,083	32,3	92,1	65	1003,3	537
3	59	0,016	13,3	98,3	49	203,4	96
4	347	0,096	37,1	90,9	42	367	5
5	900	0,250	50,7	80,1	57	1142,6	0
5_b	950	0,264	50,6	79,3	58	1244,6	0
6	449	0,125	46,3	88,7	56	524	170

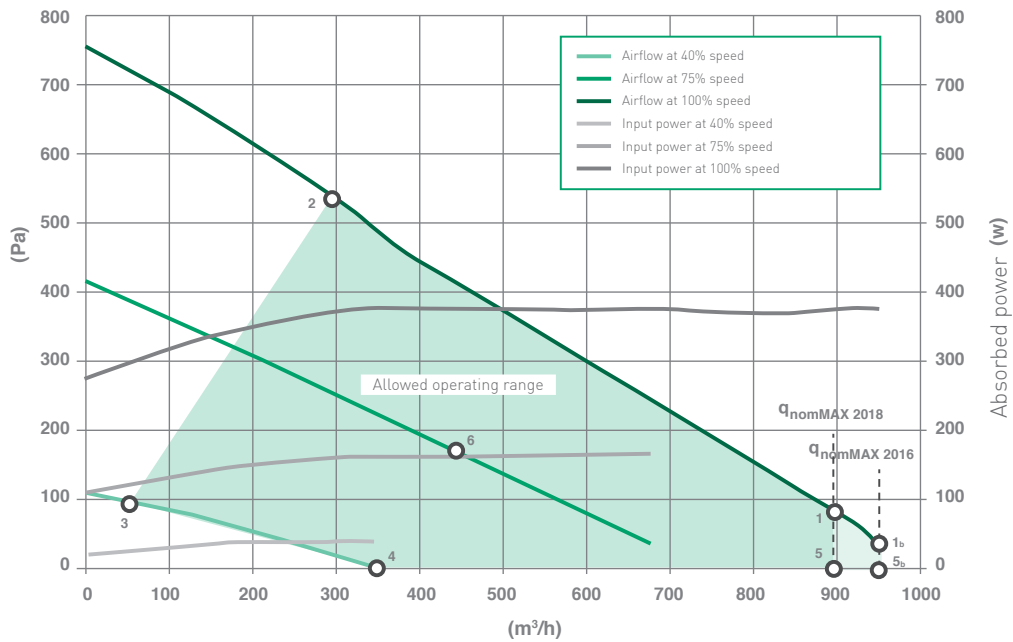

HEAT RECOVERY UNIT THERMAL EFFICIENCY

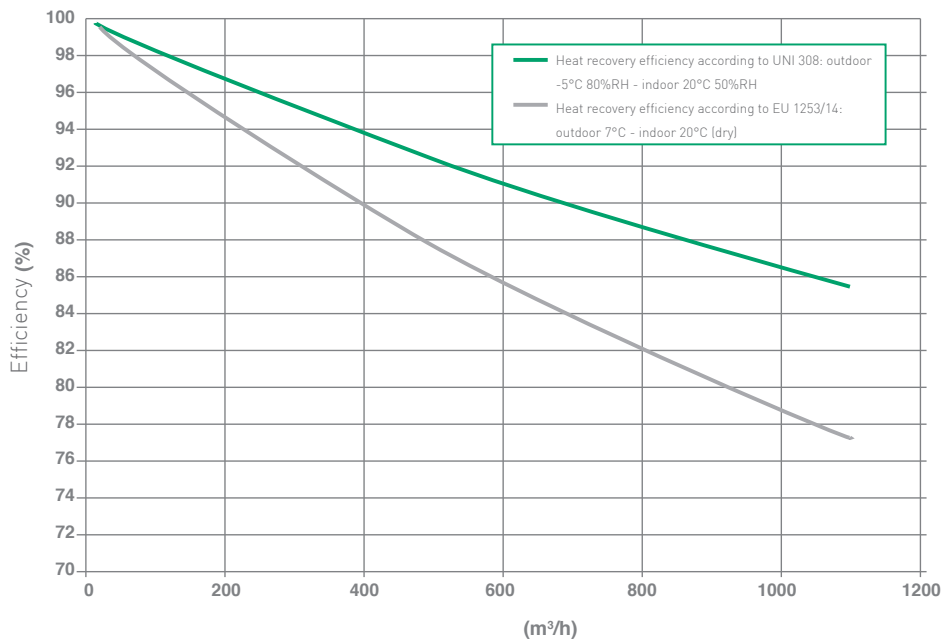

CONTROL TYPES

Electronic control board with numerous functions, including:

- speed selection 1, 2, 3 or automatic
- constant flow/pressure management option (optional)
- automatic bypass management for free-cooling and free-heating
- frost protection (also with electric heater),
- filter alarm with hour counter (optional with pressure switch)
- management of humidity, temperature, air quality, CO sensors₂...
- control of water coils and electric heaters for pre-treatment and/or post-treatment.
- ModBus communication.

Available in the following versions:

- SE on-board electronic card;
- EB white LCD display, with integrated humidity and room temperature sensors
SE+EB are included in the heat recovery unit supply
- ET colour touch-screen display (on request)

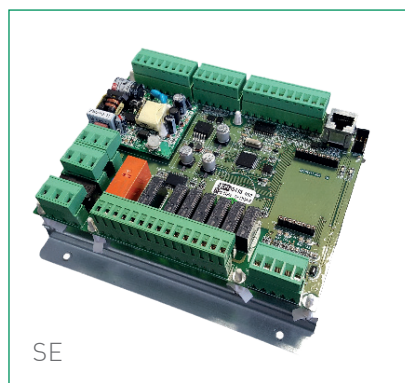

SE



EB



ET

**MVHR**Maximum air quality
in residential environment

PRODUCT DATA SHEET

Model identifier		REC R 800 H EB	REC R 800 V EB
Product type		BNVU, bidirectional	BNVU, bidirectional
Motor type		Variable speed	Variable speed
Heat recovery system		Counter-flow heat exchanger	Counter-flow heat exchanger
Heat recovery thermal efficiency*		80,1%	80,1%
Nominal air flow rate (m ³ /s)		0,25 m ³ /s	0,25 m ³ /s
Actual electrical power consumption (kW)		0,377 kW	0,377 kW
Internal specific fan power SFPint (W/(m ³ /s))*		1155 W/(m ³ /s)	1262 W/(m ³ /s)
Face velocity at nominal flow rate (m/s)*		1,67 m/s	1,67 m/s
Nominal external pressure Δs.ext (Pa)		85 Pa	55 Pa
Internal pressure drop of ventilation components Δs.int (Pa)*		294 Pa	324 Pa
Fan static efficiency η _{s,Fan} **		52,80%	52,80%
Leakage rate (%)	indoor	3,7%	3,7%
	outdoor	4,8%	4,8%
		recirculation	Not applicable
		Not applicable	Not applicable
Filter classification		fresh air F7 (ePM1 70%) extract M5 (ePM10 50%)	fresh air F7 (ePM1 70%) extract M5 (ePM10 50%)
Position and description of visual signal filter warning		Displayed alarm on the remote display	Displayed alarm on the remote display
Sound power level (L _{wa} in dB(A))		59 dB (A)	58 dB (A)









* as per regulation no. 1253/2014

** calculated as per regulation no. 1254/2014









* 3 humidity, CO sensor, air quality, presence sensor...

ACCESSORIES

Distribution accessories

	Code	Description	Minimum order
		Straight fitting (profi-air tunnel to profi-air classic)	
	TKWMVHR78313223	from 132 x 52 mm to DN 75 duct - (1)	1 pz
	TKWMVHR78313224	from 132 x 52 mm to DN 90 duct - (1)	1 pz
	TKWMVHR78313225	from DN 90 manifold to 132 x 52 mm - (2)	1 pz
		90° angle fitting (profi-air tunnel to profi-air classic)	
	TKWMVHR78313226	from 132 x 52 mm to DN 75 duct	1 pz
	TKWMVHR78313227	from 132 x 52 mm to DN 90 duct	1 pz
		PE-HD 90° angle diffuser for round grilles	
	TKWMVHR78313280	Single version, 1 x 132 x 52 mm - (1)	1 pz
	TKWMVHR78313282	Double version, 2 x 132 x 52 mm - 1 blind plug included - (2)	1 pz
		PE-HD straight diffuser for round grilles	
	TKWMVHR78313281	132 x 52 mm / Single version	1 pz
		PE-HD 90° angle diffuser for rectangular grilles	
	TKWMVHR78313285	132 x 52 mm / Discontinued version	1 pz
		Double 90° angle diffuser (flat duct => rectangular grille)	
	TKWMVHR78313286	2 x 132 x 52mm => 317 x 84mm	1 pz
		Triple 90° angle diffuser (round duct => rectangular grille)	
	TKWMVHR78300386	3 x 63 / 75 / 90 mm => 317 x 84mm Fornito con due tappi a corredo	1 pz
		Extension for double tunnel and triple classic diffuser	
	TKWMVHR78300086	Extension for 317 x 84 mm diffuser	1 pz
		Flat manifold	
	TKWMVHR78313005	5 x 132 x 52 mm, 2 x 163 x 68 (oval)	1 pz

**MVHR**Maximum air quality
in residential environment







	Code	Description	Minimum order
	TKWMVHR78316073	Concrete preparation template 2 x DN 160	1 pz
	TKWMVHR78316072	Manifold connection DN 160	1 pz
	TKWMVHR78316071	Inspection cap DN 160	1 pz
	TKWMVHR78316424	PE-HD straight double fitting (unit ducting for internal distribution) from 2 x 163 x 68 (oval) to DN 160	1 pz
	TKWMVHR78316425	PE-HD straight single fitting from 163 x 68 (oval) to DN 125	1 pz
	TKWMVHR78316401	ABS duct in 1.15 m bars 163 x 68 mm (oval)	4 pz
	TKWMVHR78316440	PE-HD vertical 90° bend 163 x 68 mm (oval)	1 pz
	TKWMVHR78316441	PE-HD horizontal 90° bend 163 x 68 mm (oval)	1 pz
	TKWMVHR78316410	PP connecting joint with sealing gaskets 163 x 68 mm (oval)	5 pz

ACCESSORIES

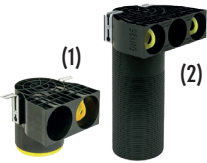
Distribution accessories









	Code	Description	Minimum order
		Flat duct (Tunnel)	
	TKWMVHR78313201	Flat duct in 3 m bars	12 m
		Corrugated ducts with HY (hygiene) antibacterial and antistatic certification	
	TKWMVHR78375805	CLASSIC GREY coil DN 75 L=50M	50 m
	TKWMVHR78390805	CLASSIC GREY coil DN 90 L=50M	50 m
		PE-HD connecting joint	
	TKWMVHR78375310	DN 75	1 pz
	TKWMVHR78390310	DN 90	1 pz
		Sealing O-ring	
	TKWMVHR78375375	DN 75	10 pz
	TKWMVHR78390375	DN 90	10 pz
		Blind plug in TP with removal grip	
	TKWMVHR78375371	DN 75 mm	5 pz
	TKWMVHR78390371	DN 90 mm	5 pz
		Flexible duct	
	GT12IANP000162	Sound-absorbing aluminium flexible duct DN 160, polyester insulated 25 mm thick - pack 10 m	10 m
		Flexible duct	
	GTSANIANP000162	Antibacterial soundproof flexible duct DN 160 in polyester-insulated aluminium - pack 10 m	10 m
		Insulated SILENT BOX plenum	
	TKWMVHR05P7101T	SILENT BOX PLUS Dim. 233X230X350 4 VIE	1 pz
	TKWMVHR05P7102T	SILENT BOX PLUS Dim. 333X230X350 6 VIE	1 pz
	TKWMVHR05P7103T	SILENT BOX PLUS Dim. 533X230X350 10 VIE	1 pz
		Flexible circular silencer	
	SCF00000000500	Flexible silencer DN 160 L 500	1 pz
	SCF00000001000	Flexible silencer DN 160 L 1000	1 pz

**MVHR**Maximum air quality
in residential environment



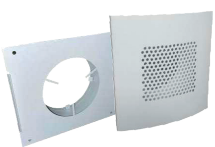



	Code	Description	Minimum order
		PE-HD 90° bend	
	TKWMVHR78375341	DN 75 - F/F convertible to M/F	1 pz
	TKWMVHR78390341	DN 90 - F/F convertible to M/F	1 pz
		PE-HD 90° angle plus diffuser for round grilles	
	TKWMVHR78375381	2 x DN 75 / DN 125 - (2)	1 pz
	TKWMVHR78375382	2 x DN 75 / DN 125 - corto - (1)	1 pz
	TKWMVHR78390381	2 x DN 90 / DN 125 - (2)	1 pz
	TKWMVHR78390382	2 x DN 90 / DN 125 - corto - (1)	1 pz
		Extension for classic plus diffuser	
	TKWMVHR78312086	Ø125	1 pz
		Concrete template	
	TKWMVHR78300081	DN 125	1 pz
		Thermally and acoustically insulated steel manifold for round ducts, supplied pre-drilled with closing plugs, usable both straight and at 90° (double starting plate)	
	TKWMVHR78316006	5+5 x DN 63/75/90, 1x DN 160, 7 tappi	1 pz
	TKWMVHR78316011	10+10 x DN 63/75/90, 1x DN 160, 14 tappi	1 pz
		Thermally insulated steel manifold for round ducts, supplied pre-cut with UVC lamp housing hole, front outlets with inspection hatch	
	TKWMVHR88316007	6 x DN 63/75/90, 1x DN 160	1 pz
	TKWMVHR88316009	8 x DN 63/75/90, 1x DN 160	1 pz
	TKWMVHR88316011	10 x DN 63/75/90, 1x DN 160	1 pz
		PE-HD manifold plug with sealing gaskets	
	TKWMVHR78300321	DN 80	1 pz
		PE-HD manifold coupling with sealing gaskets	
	TKWMVHR78375321	DN 75 - inner DN 80	1 pz
	TKWMVHR78390321	DN 90 - inner DN 80	1 pz
		Flow compensation booster (internal regulation devices in manifolds)	
	TKWMVHR78300001	DN 80 mm	1 pz

ACCESSORIES

Distribution accessories





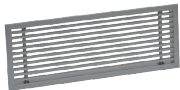
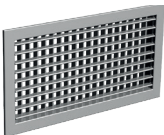

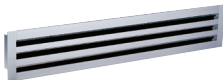

	Code	Description	Minimum order
		Dynamic air flow regulator (internal regulation devices in manifolds)	
	TKWMVHR78300015	DN 80 mm / 15 m ³ /h	1 pz
	TKWMVHR78300002	DN 80 mm / 5 m adjustment position ³ /h air flow rate 20 - 50 m ³ /h	1 pz
		Static air flow regulator (internal regulation devices in manifolds)	
	TKWMVHR78300005	DN 80 / 10 adjustment positions	1 pz
		Membrane air flow regulator	
	KVRR0800000000	DN 80 / Constant flow membrane regulator	1 pz
		Balancing damper	
	SRC00000080200	balancing damper DN 80 mm	1 pz
		White perforated wall extract/supply grille	
	88312635	DN 125 MM, filter and regulator accessories available	1 pz
		Extract air filter	
	78312692	COMPACT filter, wall/ceiling/floor, black	5 pz
		Kitchen extract air grease and oil filter	
	78312693	COMPACT filter, wall/ceiling, silver	1 pz
		COMPACT air flow regulator for installation in COMPACT mounting frame	
	78312001	DN 125	1 pz
		Adjustable round white steel supply valve	
	78312610	DN 125, mounting bracket included	1 pz

**MVHR**Maximum air quality
in residential environment

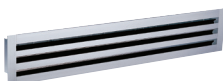
	Code	Description	Minimum order
		Adjustable round white steel extract valve	
	78312620	DN 125, mounting bracket included	1 pz
		Adjustable round white ABS extract/supply valve	
	78312630	DN 125 spring fixing	1 pz
		Filter for round valves	
	78312650	DN 125, G3	5 pz
		Steel grille for rectangular extract/supply vents	
	TKWMVHR78300640	350x130mm, wall/ceiling/floor, stainless steel finish	1 pz
	TKWMVHR78300645	350x130mm, wall/ceiling/floor, white finish	1 pz
		White perforated wall extract/supply grille	
	TKWMVHR88300645	350x130mm, white finish	1 pz
		White punched wall extract/supply grille	
	TKWMVHR88300646	350x130mm, white finish	1 pz
		Extract air filter	
	TKWMVHR78300692	Filter, wall/ceiling/floor, black	5 pz
		Fixed-blade grilles	
	BMF00002000100	Aluminium fixed horizontal bar supply/extract grille 200x100	1 pz
	BMF00002500100	Aluminium fixed horizontal bar supply/extract grille 250x100	1 pz
	BMF00003500150	Aluminium fixed horizontal bar supply/extract grille 350x150	1 pz
		Double-row supply grilles also available in RAL 9016 with code BMB	
	BMA2V002000100	Double-row aluminium blade grille 200x100	1 pz
	BMA2V002500100	Double-row aluminium blade grille 250x100	1 pz
	BMA2V003500150	Double-row aluminium blade grille 350x150	1 pz

ACCESSORIES

Distribution accessories

	Code	Description	Minimum order
	Two-slot aluminium linear diffusers		
	TDLA1D00000500	L500, with deflectors	1 pz
	TDLA1D00001000	L1000, with deflectors	1 pz
	TDLA1D00001500	L1500, with deflectors	1 pz
	Circular stamped grille		
	TDLA2D00000500	L500, with deflectors	1 pz
	TDLA2D00001000	L1000, with deflectors	1 pz
	TDLA2D00001500	L1500, with deflectors	1 pz
	Circular stamped grille		
	BDMC0000000160	Outdoor stamped grille with aluminium insect screen DN 160	1 pz
	Two-slot aluminium linear diffusers		
	TDLA1D00000500	L500, with deflectors	1 pz
	TDLA1D00001000	L1000, with deflectors	1 pz
	TDLA1D00001500	L1500, with deflectors	1 pz
	Circular stamped grille		
	TDLA2D00000500	L500, with deflectors	1 pz
	TDLA2D00001000	L1000, with deflectors	1 pz
	TDLA2D00001500	L1500, with deflectors	1 pz
	Three-slot aluminium linear diffusers		
	TDLA3D00000500	L500, with deflectors	1 pz
	TDLA3D00001000	L1000, with deflectors	1 pz
	TDLA3D00001500	L1500, with deflectors	1 pz
	Single-slot RAL 9016 white linear diffusers		
	TDLB1D00000500	L500, with deflectors	1 pz
	TDLB1D00001000	L1000, with deflectors	1 pz
	TDLB1D00001500	L1500, with deflectors	1 pz
	Two-slot RAL 9016 white linear diffusers		
	TDLB2D00000500	L500, with deflectors	1 pz
	TDLB2D00001000	L1000, with deflectors	1 pz
	TDLB2D00001500	L1500, with deflectors	1 pz
	Three-slot RAL 9016 white linear diffusers		
	TDLB3D00000500	L500, with deflectors	1 pz
	TDLB3D00001000	L1000, with deflectors	1 pz
	TDLB3D00001500	L1500, with deflectors	1 pz

**MVHR**Maximum air quality
in residential environment

	Code	Description	Minimum order
BUSINESS decorative grille			
	TKWMVHR78300660	SHAPE BUSINESS, pure white glass, 350 x 130 x 6 mm	1 pz
	TKWMVHR78312660	SHAPE COMPACT, pure white glass, Ø160 mm, 6 mm* *extract only	1 pz
SHAPE decorative grille			
	TKWMVHR78300661	SHAPE STYLE, pure white glass, 350x130x6 mm	1 pz
	TKWMVHR78312661	SHAPE CIRCLE, pure white glass, Ø160 mm, 6 mm* *extract only	1 pz
LINE decorative grille			
	TKWMVHR78300662	LINE, white (RAL 9016), 350x130x1.5 mm	1 pz
	TKWMVHR78312662	LINE COMPACT, white (RAL 9016), 160x160x1.5 mm	1 pz
SHAPE decorative grille			
	TKWMVHR78300663	LINE, satin stainless steel, 350x130x1.5 mm	1 pz
	TKWMVHR78312663	LINE COMPACT, satin stainless steel, 160x160x1.5 mm	1 pz
PYRAMID decorative grille			
	TKWMVHR78300664	PYRAMID, white (RAL 9016), 350x130x1.5 mm	1 pz
	TKWMVHR78312664	"PYRAMID COMPACT, white (RAL 9016), 160x160x1.5 mm"	1 pz
PYRAMID decorative grille			
	TKWMVHR78300665	PYRAMID, dark rust bronze, 350x130x1.5 mm	1 pz
	TKWMVHR78312665	PYRAMID COMPACT, dark rust bronze, 160x160x1.5 mm	1 pz
AVANTGARDE decorative grille			
	TKWMVHR78300666	AVANTGARDE, white (RAL 9016), 350x130x1.5 mm	1 pz
	TKWMVHR78312666	"AVANTGARDE COMPACT, white (RAL 9016), 160x160x1.5 mm"	1 pz
AVANTGARDE decorative grille			
	TKWMVHR78300667	AVANTGARDE, satin stainless steel, 350x130x1.5 mm	1 pz
	TKWMVHR78312667	AVANTGARDE COMPACT, satin stainless steel, 160x160x1.5 mm	1 pz
FLORA decorative grille			
	78300668	FLORA, white (RAL 9016), 350x130x1.5 mm	1 pz
	78312668	FLORA COMPACT, white (RAL 9016), 160x160x1.5 mm	1 pz
FLORA decorative grille			
	78300669	FLORA, anthracite, 350x130x1.5 mm	1 pz
	78312669	FLORA COMPACT, anthracite, 160x160x1.5 mm	1 pz

ACCESSORIES

Distribution accessories

	Code	Description	Minimum order
	TKWMVHR78300670	HORIZON, white pure glass, 350x130x5.5 mm	1 pz
	TKWMVHR78312670	TWIST COMPACT, white pure glass, 160x160x5.5 mm	1 pz
Decorative grille in powder blue glass			
	TKWMVHR78300671	HORIZON, powder blue glass, 350x130x5.5 mm	1 pz
	TKWMVHR78312671	TWIST COMPACT, powder blue glass, 160x160x5.5 mm	1 pz
Decorative grille in light brown glass			
	TKWMVHR78300672	HORIZON, light brown glass, 350x130x5.5 mm	1 pz
	TKWMVHR78312672	TWIST CIRCLE, light brown glass, Ø160, 5.5 mm	1 pz
Decorative grille in black & white glass			
	TKWMVHR78300673	HORIZON, black & white glass, 350x130x5.5 mm	1 pz
	TKWMVHR78312673	TWIST COMPACT, black & white glass, 160x160x5.5 mm	1 pz
	TKWMVHR78312674	TWIST CIRCLE, black & white glass, Ø160, 5.5 mm	1 pz
Decorative grille in satin white pure glass			
	78300675	STRIPES, satin white pure glass, 350x130x5.5 mm	1 pz
	78312675	TWIST CIRCLE, satin white pure glass, Ø160, 5.5 mm	1 pz
Decorative grille in satin black glass			
	TKWMVHR78300676	STRIPES, satin black glass, 350x130x5.5 mm	1 pz
	TKWMVHR78312676	TWIST COMPACT, satin black glass, 160x160x5.5 mm	1 pz
CROSS decorative grille in satin white pure glass			
	TKWMVHR78300677	CROSS, satin white pure glass, 350x130x5.5 mm	1 pz
	TKWMVHR78312677	CROSS CIRCLE, satin white pure glass, Ø160, 5.5 mm	1 pz
CROSS decorative grille in satin bronze glass			
	TKWMVHR78300678	CROSS, satin bronze glass, 350x130x5.5 mm	1 pz
	TKWMVHR78312678	CROSS CIRCLE, satin bronze glass, Ø160, 5.5 mm	1 pz
CROSS decorative grille in blue-gray glass			
	TKWMVHR78300679	CROSS, blue-gray glass, 350x130x5.5 mm	1 pz
	TKWMVHR78312679	CROSS CIRCLE, blue-gray glass, Ø160, 5.5 mm	1 pz
CROSS decorative grille in blue-gray glass			
	TKWMVHR78300695	Mounting frame, wall/floor, black, 317x84mm	1 pz
	TKWMVHR78312695	COMPACT plus mounting frame, black, on all DN 125 mm outlets, 35 mm	1 pz

**MVHR**Maximum air quality
in residential environment

	Code	Description	Minimum order
		Stainless steel floor mounting frame for starline plus rectangular grilles	
	TKWMMVHR78300699	Height-adjustable, filter flow and static regulator flow. 350x130x50 mm Floor mounting. Black, AVANTGARDE and LINE grilles only	1 pz 1 pz
		Extract air filter	
	TKWMMVHR78300692	Filter, wall/ceiling/floor, black	5 pz
	TKWMMVHR78312692	COMPACT filter, wall/ceiling/floor, black	5 pz
		Kitchen extract air grease and oil filter	
	TKWMMVHR78300693	Filter, wall/ceiling, silver	1 pz
	TKWMMVHR78312693	COMPACT filter, wall/ceiling, silver	1 pz
		Static air flow regulator	
	TKWMMVHR78312001	9 adjustment holes	1 pz
	TKWMMVHR78300007	COMPACT, DN 125, 7 adjustment holes	1 pz
		Stainless steel external wall grille	
	TKWMMVHR78312174	DN 125 mm, stainless steel	1 pz
	TKWMMVHR78312176	DN 125 mm, white steel	1 pz
	TKWMMVHR78316174	DN 160 mm, stainless steel	1 pz
	TKWMMVHR78316176	DN 160 mm, white steel	1 pz
	TKWMMVHR78318174	DN 180 mm, stainless steel	1 pz
	TKWMMVHR78318176	DN 180 mm, white steel	1 pz
		Stainless steel external wall grille with deflector shell	
	TKWMMVHR88312170	DN 125 mm	1 pz
	TKWMMVHR88315170	DN 150 mm	1 pz
	TKWMMVHR88316170	DN 160 mm	1 pz
	TKWMMVHR88318170	DN 180 mm	1 pz
	TKWMMVHR88320170	DN 200 mm	1 pz
		Steel roof tile for flat roof terminal	
	TKWMMVHR78316180	DN 160/180 mm	1 pz
		PVB roof tile for sloped roof terminal with adjustable inclination	
	TKWMMVHR78316184	25° => 55° DN 160/180 mm	1 pz
		Insulated stainless steel roof terminal	
	TKWMMVHR78300175	DN 160/180 mm, black	1 pz

Terms of sale

The general conditions of sale indicated below are considered valid and accepted regardless of the particular clauses and conditions provided for in the customer's order, unless otherwise agreed by the company in writing.

Price and payment terms

1. Unless otherwise specified, our price lists are purely indicative and may be modified in relation to any increases in labour, raw material and other cost elements that may occur from the date of contract conclusion to the date of goods shipment.
2. The prices indicated are net of VAT, packaging and transport costs and any other charges including tax, not expressly borne by contract or by law, by Teknowool Air.
3. For orders below 150 euros net taxable goods, payment must be made in cash, cash on delivery or advance bank transfer.
4. All payments shall be made by the customer at the current and future headquarters of Teknowool Air, against issuance of an invoice or other accounting document.
The issuance of bank receipts and promissory notes will not change the place of payment, which will remain the headquarters of Teknowool Air.
5. Late payment entitles Teknowool Air, without the need for formal notice, to charge the Customer default interest at the conventional rate equal to the highest "Prime Rate" applied on the day of actual payment by regional banks (BIN), plus 5%. In such case, Teknowool Air is also granted the right to withdraw from the contract without any compensation by simple notice via registered letter, with the customer being obliged to immediately return products already delivered.
6. Set-offs are not permitted. Any deferred payments may not be delayed or suspended even in cases of disputes, claims or delays by Teknowool Air.
7. Teknowool Air reserves the right to suspend and/or cancel orders in progress if there are uncertainties about the buyer's solvency, subject to making delivery conditional on advance payment or the provision of suitable guarantees.

Delivery

8. Delivery, unless otherwise agreed, shall be made ex-works by Teknowool Air, packaging excluded. Even in the case of delivery to destination, the delivery is considered completed at Teknowool Air.
9. Transport risks are always borne by the customer.
10. Delivery is considered completed from the day after the notice that goods are ready for transport.
11. Delivery times are purely indicative and not binding. Teknowool Air reserves the right to postpone delivery without this constituting grounds for contract termination or compensation for damages.
12. We reserve the right to partially fulfil orders received and to issue separate invoices for individual deliveries made.
13. Teknowool Air, due to force majeure, including strikes, production plant failures and other causes attributable to third parties, reserves the right to reduce the supply quantities, postpone the delivery date or terminate the contract, without the customer being entitled to any compensation for damages.

Claims and warranties

14. The buyer must verify within 7 days of delivery that the supply corresponds to the product ordered. After this period, no complaints can be raised regarding the non-correspondence of the delivered product to what was ordered.
15. All complaints concerning products delivered and sold must be received by Teknowool Air in writing within seven days of delivery, via registered letter with return receipt, under penalty of forfeiture. Complaints cannot in any case justify late or non-payment. Shortages and damage must be reported to the carrier at the time of delivery.
16. It is expressly agreed that Teknowool Air's warranty consists of the repair of the supplied product or its possible replacement, services which replace in all respects the warranties provided by law, which are

expressly excluded together with the consequent rights to contract termination, damage compensation or price reduction.

17. Teknowool Air guarantees its products against manufacturing defects according to current European standards. The warranty is limited to the replacement or repair of products found to be originally defective; the cost of labour, travel and accommodation expenses for any technical staff trips by Teknowool Air are borne by the customer. Parts to be repaired or replaced must be sent carriage paid to Teknowool Air. Parts to be repaired or replaced will be delivered to the customer carriage forward.
18. Teknowool Air reserves the right to modify technical and dimensional data without prior notice.

Jurisdiction

19. The court of Padova has exclusive jurisdiction over any dispute arising from or related to this contract.

TEKNOWOOL AIR Srl
www.teknowoolair.com

Via Marconi, 1 - 35020 Legnaro PD
P.IVA e CF: 04888500289 - Tel. +39 049 641679
commerciale@teknowoolair.com



Ventilation



Diffusion



Filtration



Fire & Smoke

