

Overpressure damper



Product

SSC

Construction

Galvanized steel sheet casing, aluminium opening blades with spring actuation and internally fixed rubber gasket

SPECIFICATION

Circular duct overpressure damper

MOUNTING

Push-in

DIMENSIONAL

mm	Ø D mm	L mm	L1 mm	Wt. kg
100	98	88	26	0,13
125	123	88	19	0,17
150	148	88	31	0,22
160	158	88	36	0,24
200	198	88	56	0,29
250	248	128	61	0,68
315	313	128	94	0,81
400	398	198	94	1,68

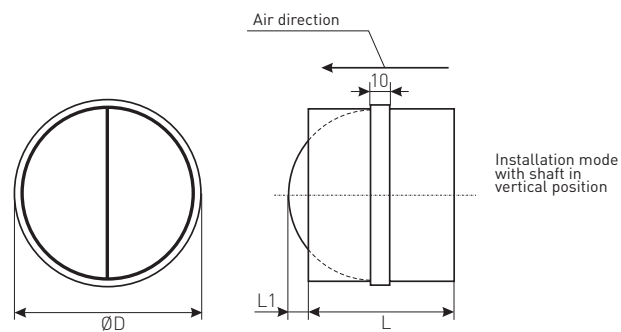

SSC



Diffusion

Components
for perfect air
distribution in HVAC
systems

SELECTION DIAGRAM

