

# BLAI

## Industrial air curtain



<b>Product</b>	BLAI
<b>Lengths</b>	165, 220 e 275 cm
<b>Air flow rate</b>	Up to 18,500 m <sup>3</sup> /h

### SPECIFICATION

High performance air curtains, for use in industrial buildings, storage areas, hangars, garages, warehouses refrigerated.

The curtain effect is maximized thanks to the exclusive "straw system" which gives the air a linear, straight motion, with modest lateral deviations.

### APPLICATION

Modular structure designed for installation in industrial environments with dedicated assembly and support.

In the electric heating version, wire electric heating elements are used, without inertia, with virtually immediate heating.

Various types of air velocity and heating system control are available.

### CHARACTERISTICS

- Galvanised steel structure painted RAL 9010 (any RAL colour on request).
  - Horizontal and vertical installation.
- In the case of vertical installation beside the door, installing two opposed air curtains protects openings up to 12 m wide.
- The supply can be completed with wall or ceiling mounting brackets that also allow the airflow direction of the air curtain to be adjusted to better counteract the incoming air force
  - W: Water heating.
  - E: Electric heating.
  - S: without heating.
- The air throw effectively protects openings up to 6 m wide.



WATER HEATING



ELECTRIC HEATING



WITHOUT HEATING

**PERFORMANCE UNDER STANDARD CONDITIONS****MAXIMUM INSTALLATION HEIGHT/WIDTH 6M**

Model	Air flow rate m <sup>3</sup> /h	Sound pressure* dB(A)		Heating power kW	Heater electric V/A	Motors V/A	Wt. kg
		3 m	4m				
BLAI-150-S	11550	67,5	63,0	-	-	230/3,6	51
BLAI-150-V	10300	67,5	63,1	75,2**	-	230/3,7	60
BLAI-150-E	11550	67,5	63,0	24,3	400/35,2	230/3,6	55
BLAI-200-S	15100	69,3	64,9	-	-	230/4,8	69
BLAI-200-V	13700	68,4	64,0	101,0**	-	230/5,0	78
BLAI-200-E	15100	69,3	64,9	32,4	400/47,0	230/4,8	74
BLAI-250-S	18500	71,1	66,7	-	-	230/6,0	83
BLAI-250-V	17000	70,0	65,5	127,0**	-	230/6,3	98
BLAI-250-E	18500	71,1	66,7	40,5	400/58,6	230/6,0	89

\* Sound pressure according to EN ISO 11203. Values measured at 3 or 5 m distance from the unit with directional coefficient Q = 2

\*\* With water temperature 90-70 °C and inlet air temperature = 15 °C

**ELECTRIC COIL PARAMETERS**

Model	Air flow rate m <sup>3</sup> /h	Heating power kW	Air temperature increase* °C
BLAI-150-S	11550	24,3	6,3
BLAI-200-V	15100	32,4	6,4
BLAI-250-E	18500	40,5	6,5

\* At maximum air flow rate, and with maximum electrical power

**WATER COIL PARAMETERS FOR TEMPERATURE DIFFERENCE 90/70°C**

Model	Air flow rate m <sup>3</sup> /h	Thermal output kW	Outlet temperature °C	Pressure drop kPa	Water flow rate l/s
BLAI-150-V	10300	75,2	38,1	24	0,92
BLAI-200-V	13700	101	38,4	17	1,24
BLAI-250-V	17000	127	38,7	15	1,55

**Note:** with inlet air temperature +15°C

## WATER COIL PARAMETERS FOR TEMPERATURE DIFFERENCE 80/60°C

Model	Air flow rate m <sup>3</sup> /h	Thermal output kW	Outlet temperature °C	Pressure drop kPa	Water flow rate l/s
BLAI-150-V	10300	62,9	34,1	18	0,76
BLAI-200-V	13700	84,6	34,3	14	1,03
BLAI-250-V	17000	106	34,5	11	1,29

\* With air inlet temperature +15°C.

## WATER COIL PARAMETERS FOR TEMPERATURE DIFFERENCE 70/50°C

Model	Air flow rate m <sup>3</sup> /h	Thermal output kW	Outlet temperature °C	Pressure drop kPa	Water flow rate l/s
BLAI-150-V	10300	50,4	30,1	13	0,61
BLAI-200-V	13700	67,6	30,2	9	0,82
BLAI-250-V	17000	84,5	30,4	9	1,03

\* With air inlet temperature +15°C.

## WATER COIL PARAMETERS FOR TEMPERATURE DIFFERENCE 60/40°C

Model	Air flow rate m <sup>3</sup> /h	Thermal output kW	Outlet temperature °C	Pressure drop kPa	Water flow rate l/s
BLAI-150-V	10300	37,6	26,1	8	0,45
BLAI-200-V	13700	50,2	26,2	7	0,61
BLAI-250-V	17000	62,7	26,2	5	0,76

\* With air inlet temperature +15°C.



Diffusion

Components  
for perfect air  
distribution in HVAC  
systems

## DIMENSIONS

### 1A...E1...

Model	A mm	B mm
150	1650	320
200	2200	870
250	2750	870

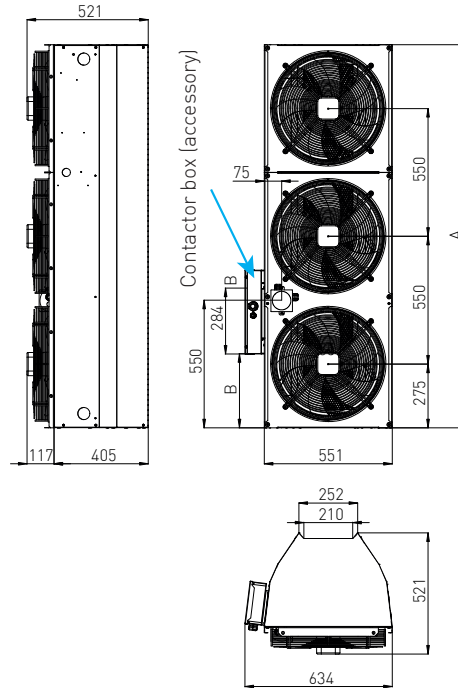

### 1A...S0...

Model	A mm
150	1650
200	2200
250	2750

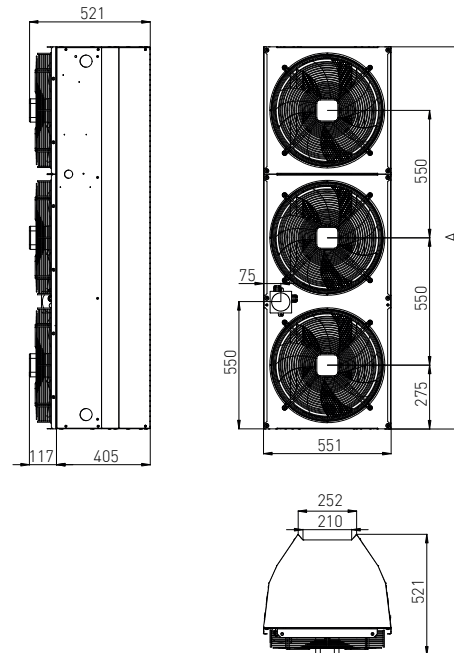

# BLAI

Industrial air curtain

1A...V2...

Model	A mm	B mm
150	1650	1526
200	2200	2076
250	2750	2626

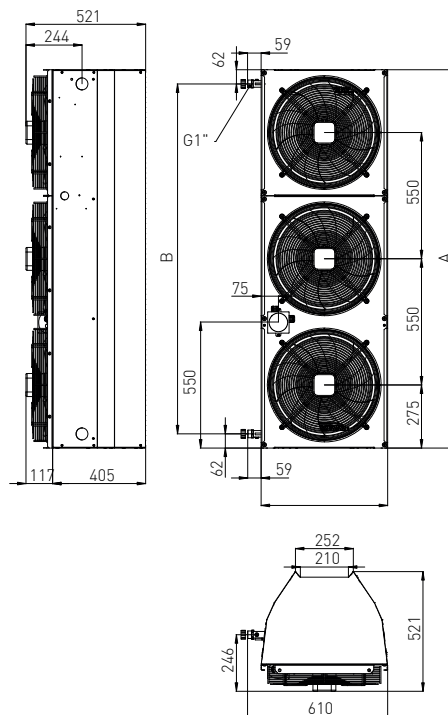

## INSTALLATION

HORIZONTAL CEILING MOUNTING (THREADED RODS NOT SUPPLIED)

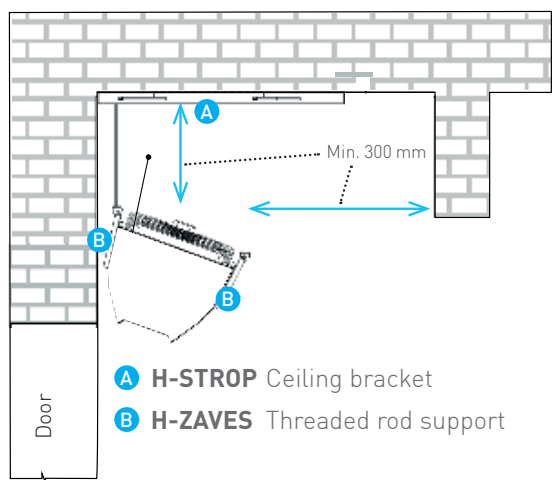

- A** H-STROP Ceiling bracket
- B** H-ZAVES Threaded rod support

H-STROP Kit consisting of 1 ceiling bracket **A** and 2 supports for threaded rod **B**

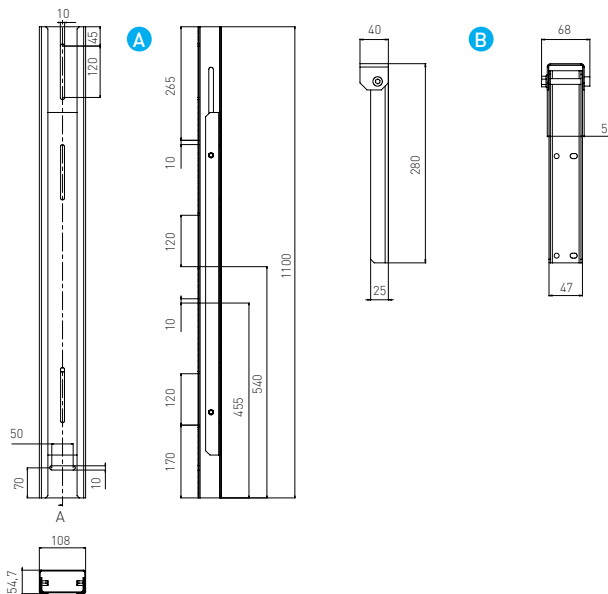

Number of modules connected in line	1	2	3	4	5	6	7	...	N
Number of support kits required	2	3	4	5	6	7	8	...	N+1

Code: 1-KOT-H-STROP-0 (0 = standard RAL9010; 1 = galvanized sheet; 2 = any special RAL)



**Diffusion**

Components  
for perfect air  
distribution in HVAC  
systems

**HORIZONTAL WALL MOUNTING (THREADED RODS NOT SUPPLIED)**

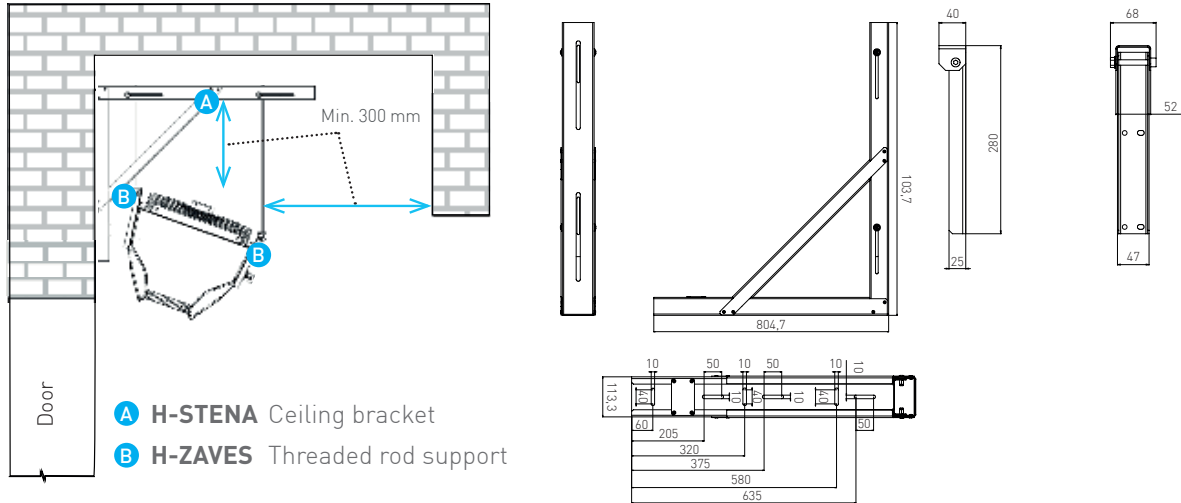

- A** H-STENA Ceiling bracket
- B** H-ZAVES Threaded rod support

**H-STENA Wall support kit** consisting of 1 bracket at 90° **A** and 2 supports for threaded rod **B**

Number of modules connected in line	1	2	3	4	5	6	7	...	N
Number of support kits required	2	3	4	5	6	7	8	...	N+1

**Code: 1-KOT-H-STROP-0** (0 = standard RAL9010; 1 = galvanized sheet; 2 = any special RAL)

**HORIZONTAL MOUNTING (THREADED RODS NOT SUPPLIED)**

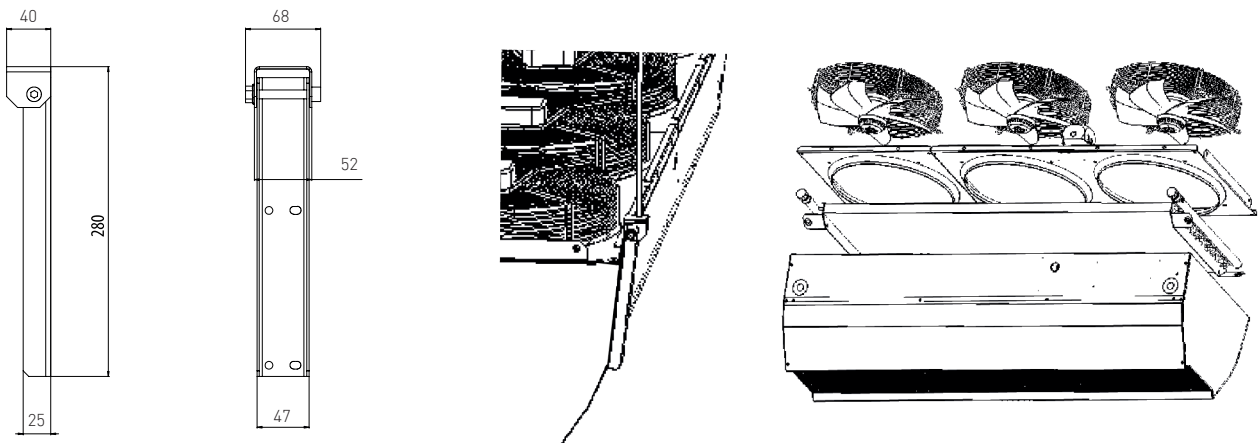

**H-ZAVES** Threaded rod support

If no horizontal support kit has been ordered (see above) it is nevertheless possible to order the brackets for threaded rod attachment

Number of modules connected in line	1	2	3	...	N
Number of brackets	4	6	8	...	N*2+2

**Code: KOT-H-ZAVES-0** (0 = standard RAL9010; 1 = galvanized sheet; 2 = any special RAL)

