

FANLINE

Polypropylene inline extractor



FANLINE



Product

FANLINE

Application

Civil applications

Construction

Impeller and structure in polypropylene



FANLINE VERSION EC

SPECIFICATIONS

Inline fan suitable for air renewal in bathrooms and small enclosed rooms.

Operating temperature range: -25°C to +60°C.

Protection class: IPX4.

MOTOR

Single-phase motor, 3 speeds, equipped with ball bearings, with impeller and terminal box fixed to the structure with locking devices and easily removable.

Standard voltages 230 V 50 Hz.

Integrated thermostatic switch. Mounting bracket included.

VERSIONS

EC version on request.

APPLICATIONS



CIVIL VENTILATION



FAST FOOD



CANTEENS



RESTAURANTS



GARAGE

TECHNICAL FEATURES - OPERATING RANGE

Operating range	Flow rate (m ³ /h)	From 100 to 3.000
	Pressure (Pa)	Up to 600
Motor	Volt (±10%)	230 V
Max. operating temperature	°C	50



QUICK SELECTION TABLE

FANLINE Model	Speed max. RPM	Power supply V/Hz	Max. allowed current A	Power max. kW	Flow rate max. m ³ /h	Sound power dB(A)	Wt. approx. kg
150L	2730	230/50	0.3	0,046	600	69	2,4
160L	2820	230/50	0.3	0,045	615	66	2,5
200	2850	230/50	0.6	0,117	1220	72	4
250	2880	230/50	0.8	0,170	1625		5,7
315	2850	230/50	2.1	0,436	3180	82	12,4
400	3300	230/50	1	0,211	3300	71	15,27

DIMENSIONS

FANLINE Model	A mm	B mm	C mm	D mm	E mm	F mm
150L	Ø150	390	238,5	94	100	4x Ø5
160L	Ø160	289	238,5	94	100	4x Ø5
200	Ø200	325	280	120	125	4x Ø5
250	Ø250	215	299	80	125	4x Ø5
315	Ø315	300	361	210	264	4x Ø9
400	Ø400	350	452	225	330	4x Ø9

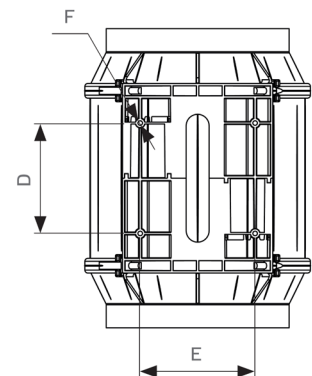
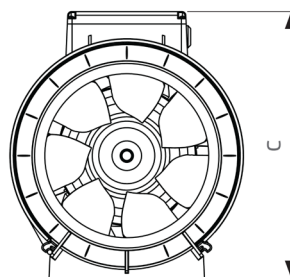
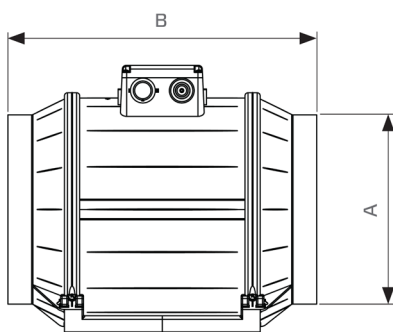

CHARACTERISTIC CURVES

FANLINE 150

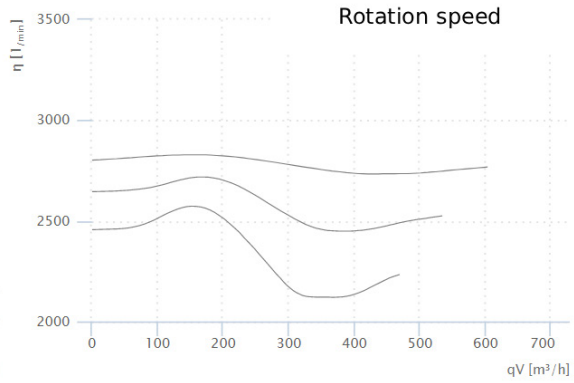
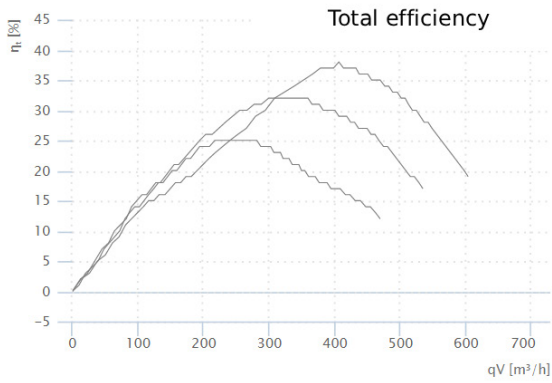
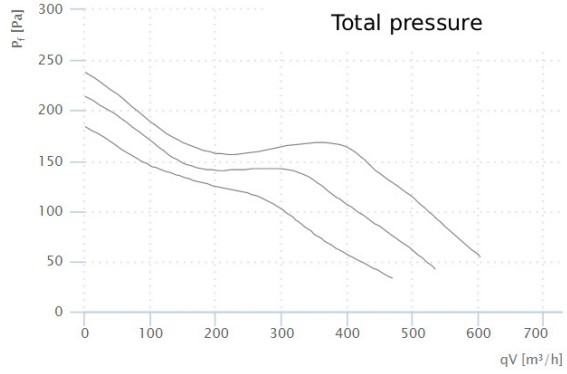
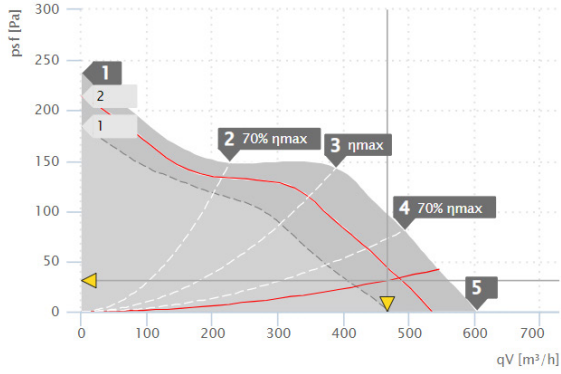

FANLINE 160

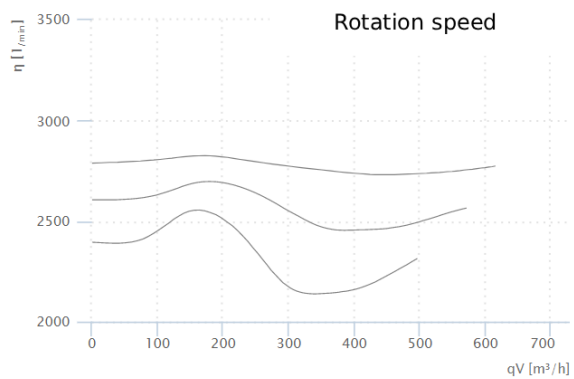
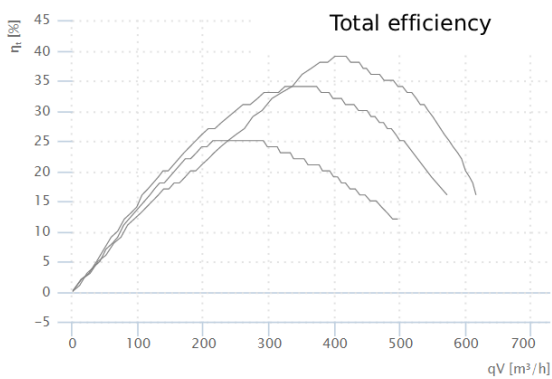
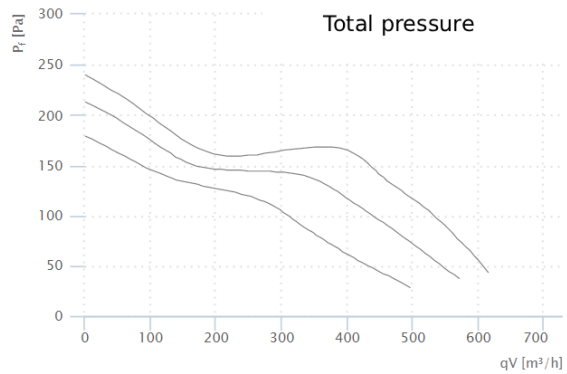
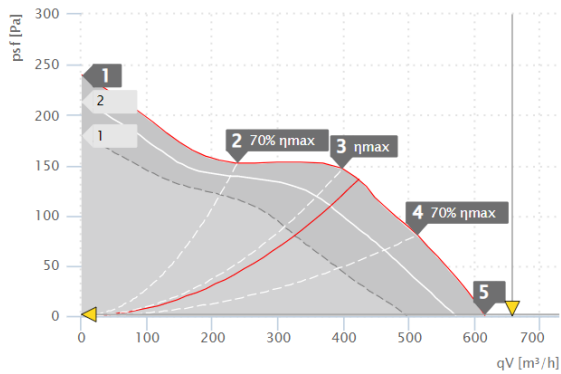



FANLINE 200

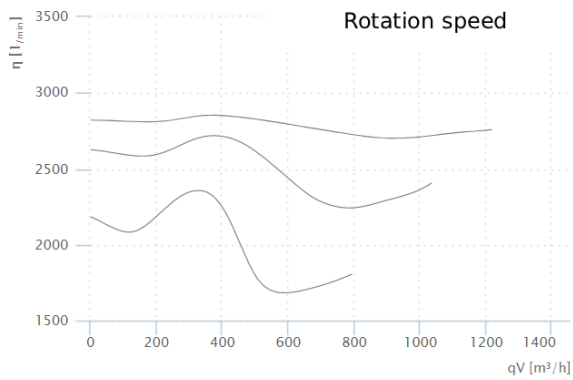
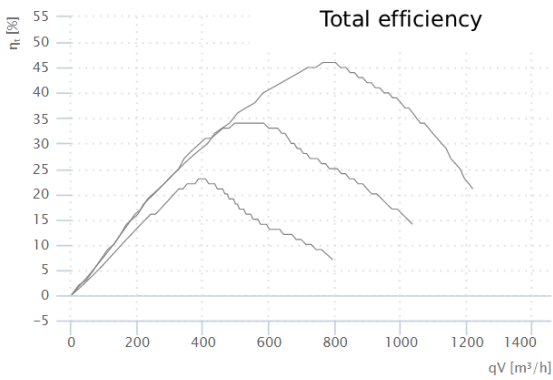
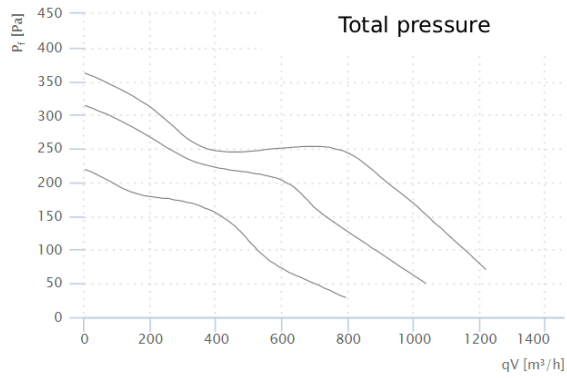
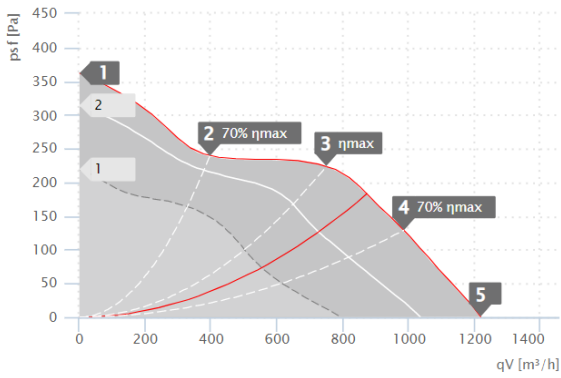

FANLINE 250

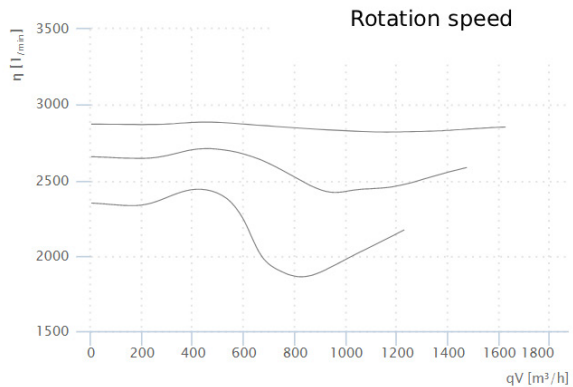
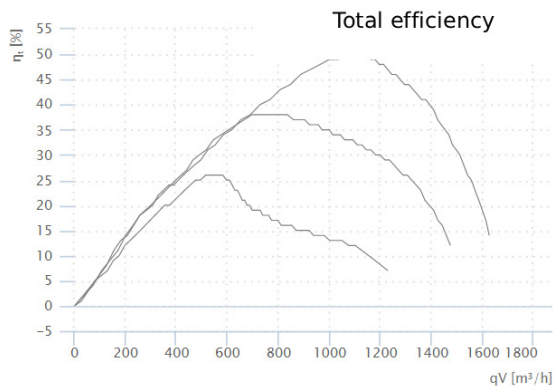
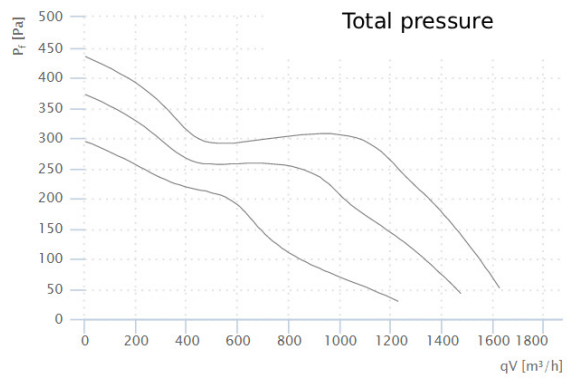
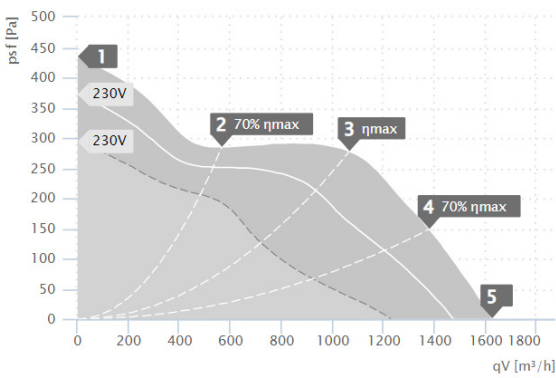

FANLINE 315

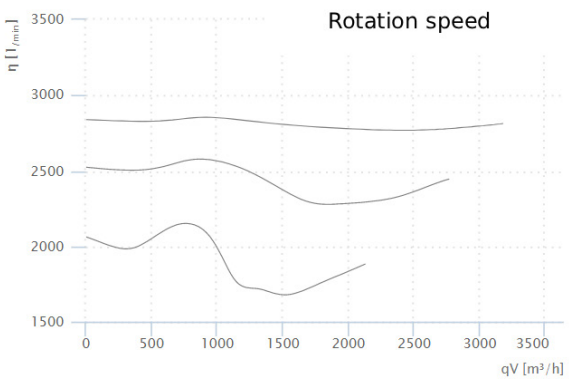
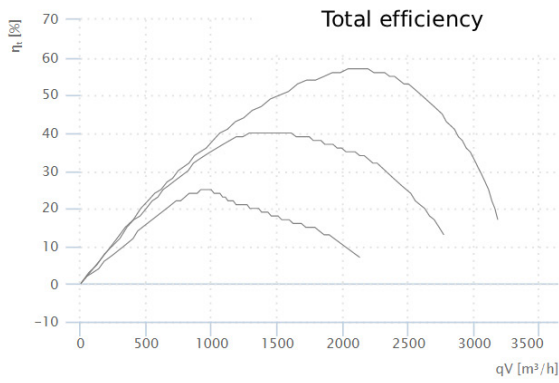
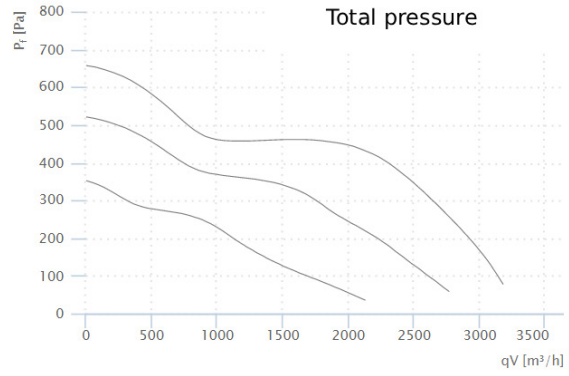
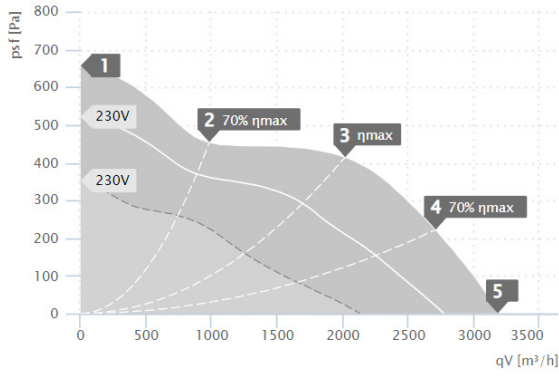

FANLINE 400

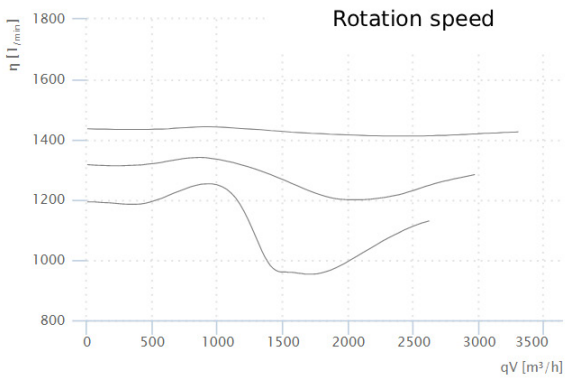
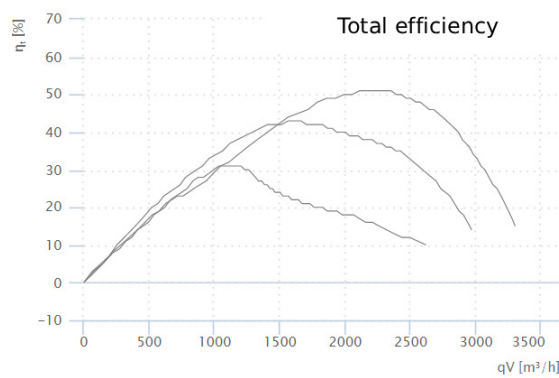
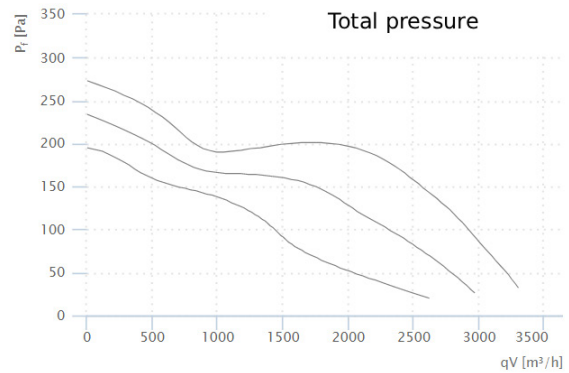
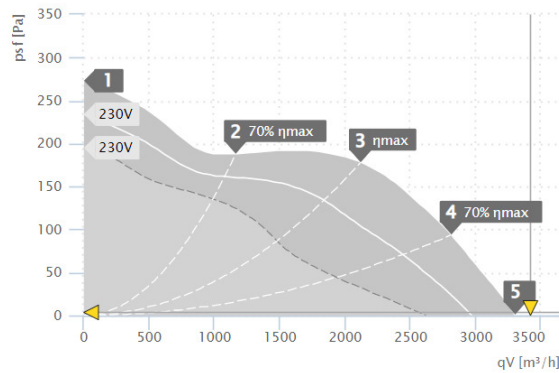



ACCESSORIES



4-stage start-stop selector (0-1-2-3)



Safety start/stop switch
to stop the fan before any maintenance work.
Compliant with IEC 947-3 standard.
Protection IP-65

All images are only indicative of the product type and may differ from the actual article.