

REC R 220

Centralized heat recovery unit with controls 220 m³/h



Vertical



Horizontal

DESCRIPTION

Centralized heat recovery unit with plug-and-play wireless controls and integrated bypass. Self-supporting structure in pre-painted sheet metal, thermal/acoustic insulation in 22 mm rock wool.

HEAT EXCHANGE CORE

Counter-flow heat exchange core, in polypropylene, with efficiency >90% in optimal ambient conditions.

FANS

EC fans, backward-curved centrifugal, low consumption.

Product

REC R 220 H/V

Installation

Horizontal/Vertical

Efficiency ratings

> 90%

FILTERS

F7 (ePM1 70%) filters with low pressure drop, for both extract and fresh air.

TECHNICAL SPECIFICATIONS

Parameter description	Unit of measurement	Values
Air flow rate	mc/h	269
Available static pressure	Pa	100
Thermal efficiency	%	>90
Nominal voltage	V	230 – 1F
Frequency	Hz	50-60
Consumption at maximum flow rate	A	1.5
Nominal power	W	173
Filters	Class	F7 (ePM1 70%)

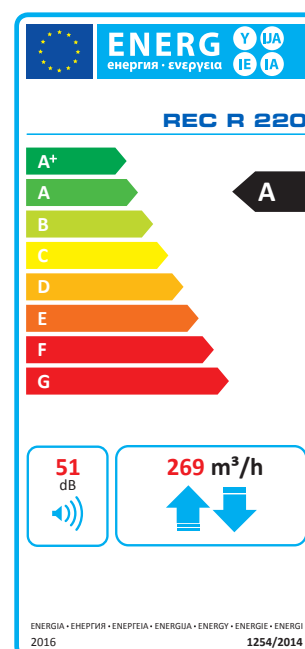



MVHR

Maximum air quality
in residential environment

DIMENSIONS

Horizontal version (H)

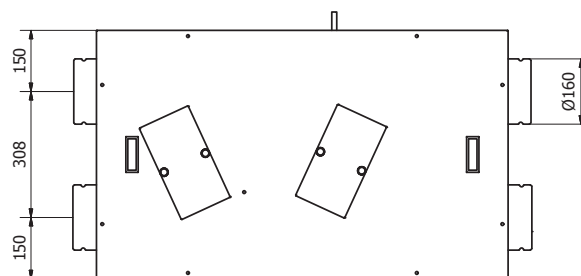
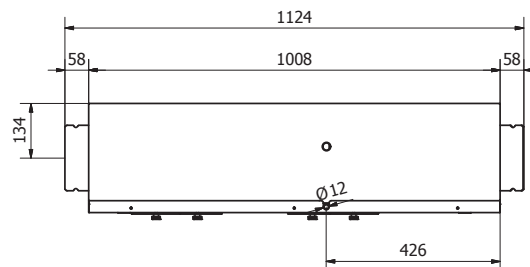
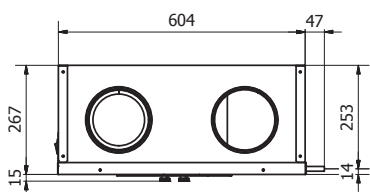
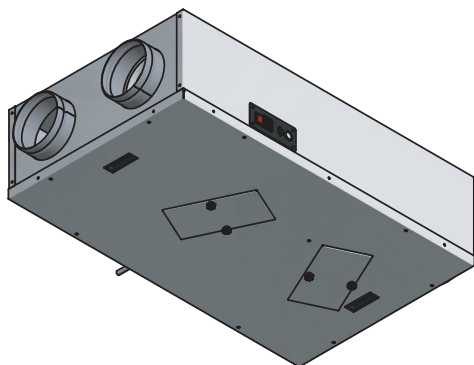

CONFIGURATIONS

Nominal duct diameter: Ø 160 mm Weight: 42 kg
Sound pressure level at 1.5 m (L_{pA} in dB(A)): 39 dB(A)

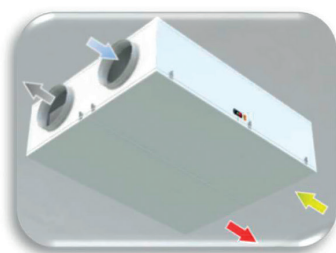

HS (standard)
CEILING

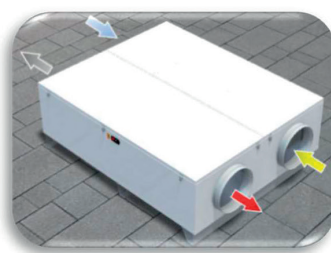

HB
BASE



HP
WALL

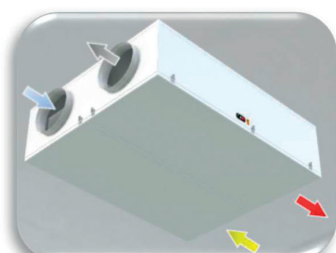

KS*
CEILING

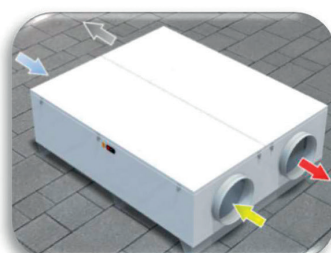

KB*
BASE

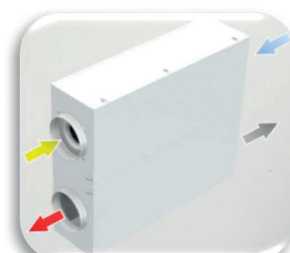

KP*
WALL

LIGHT BLUE	RENEWAL (outdoor air intake)	YELLOW	RETURN (extraction from the room)
GREY	EXHAUST (exhaust to outside)	RED	SUPPLY (room supply)

DIMENSIONS

Vertical version (V)

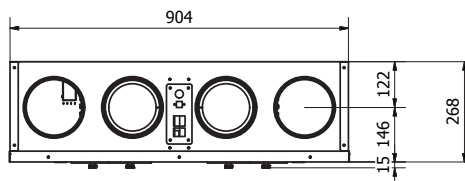
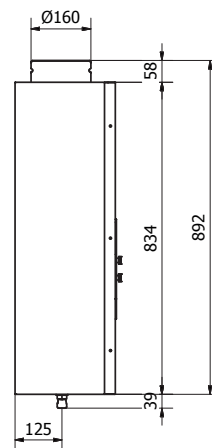
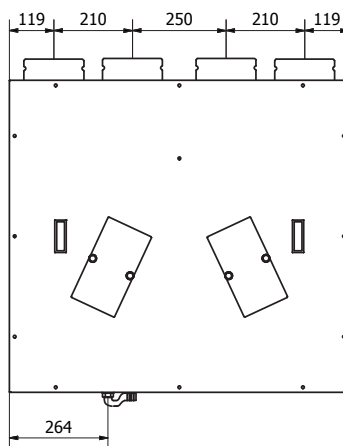
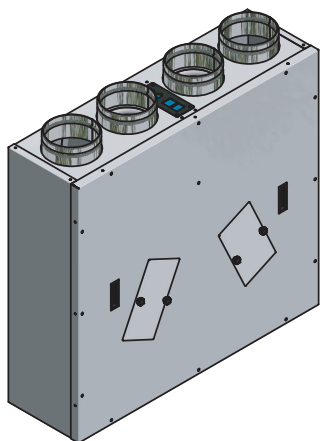

CONFIGURATIONS

Nominal duct diameter: Ø 160 mm Weight: 53 kg
 Sound pressure level at 1.5m (L_{pa} in dB(A)): 39 dB(A)

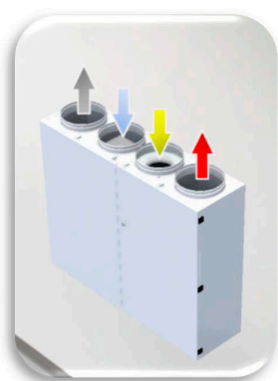

VA (standard)
WALL

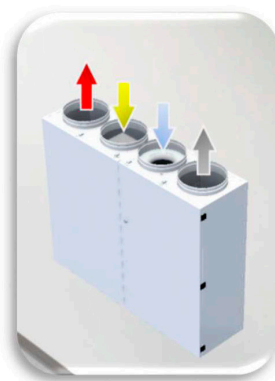

VB*
WALL

LIGHT BLUE	RENEWAL (outdoor air intake)	YELLOW	RETURN (extraction from the room)
GREY	EXHAUST (exhaust to outside)	RED	SUPPLY (room supply)



MVHR

Maximum air quality
in residential environment

AERAUIC PERFORMANCE

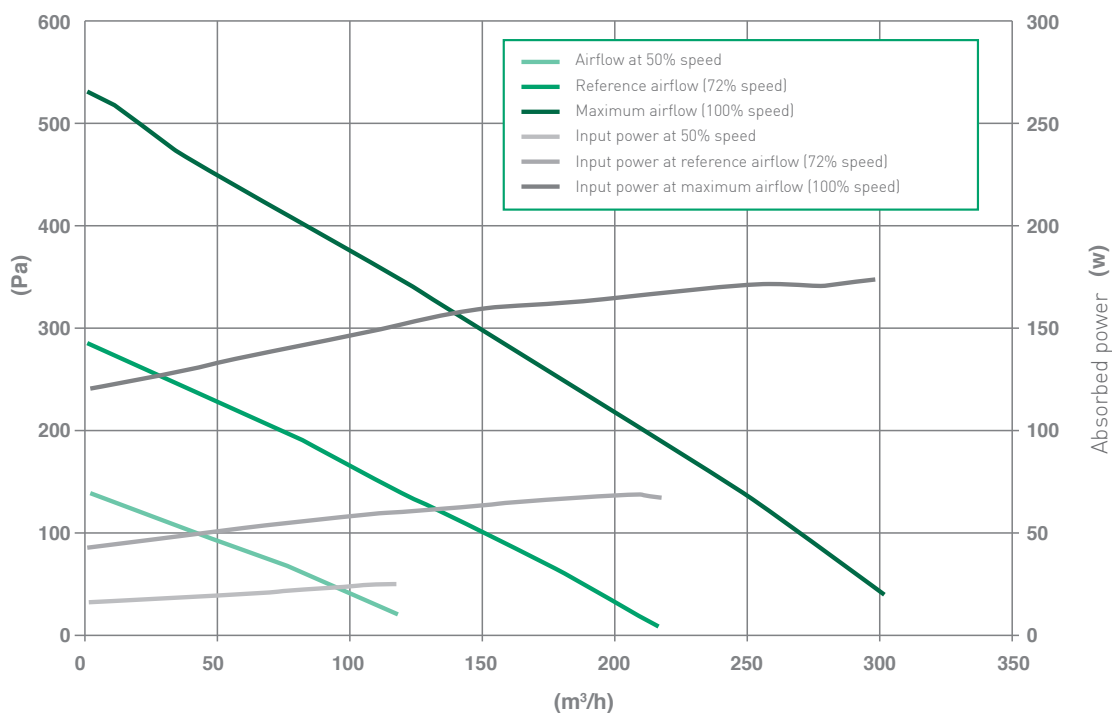

HEAT RECOVERY UNIT THERMAL EFFICIENCY

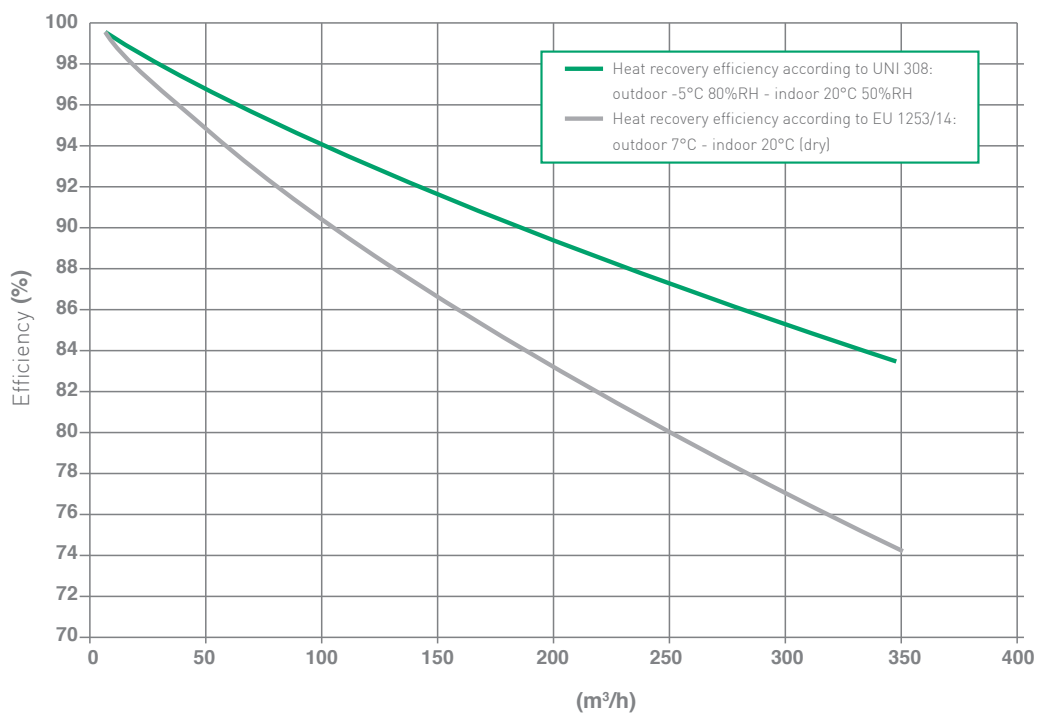

CONTROL TYPES

Electronic control board with numerous functions, including:

- speed selection 1, 2, 3 or automatic
- constant flow/pressure management option (optional)
- automatic bypass management for free-cooling and free-heating
- frost protection (also with electric heater),
- filter alarm with hour counter (optional with pressure switch)
- management of humidity, temperature, air quality, CO sensors₂...
- control of water coils and electric heaters for pre-treatment and/or post-treatment.
- ModBus communication.

Available in the following versions:

- SE on-board electronic card;
- EB white LCD display, with integrated humidity and room temperature sensors
SE+EB are included in the heat recovery unit supply
- ET colour touch-screen display (on request)

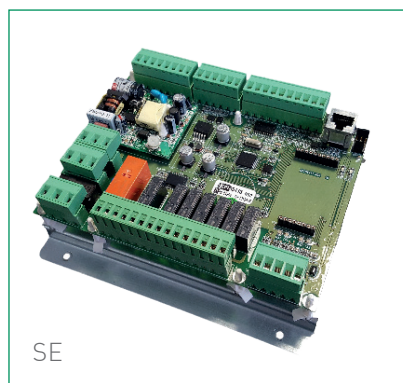

SE



EB



ET

**MVHR**Maximum air quality
in residential environment**PRODUCT DATA SHEET**

Model identifier		REC R 220 H/V EB
Specific energy consumption in kWh/(m ² .a) per zone climate and SEC class	Cold climate Mild climate Hot climate	-73,7 kWh/m ² .a -36,4 kWh/m ² .a -12,4 kWh/m ² .a
Energy class		A
Product type		BVU, bidirectional
Motor type		Variable speed
Heat recovery system		Counter-flow heat exchanger
Heat recovery thermal efficiency*		83,9%
Maximum air flow rate (m ³ /h)*		269 m ³ /h
Electrical power consumption at maximum flow rate (W)*		173 W
Sound power level (L _{wa} in dB(A))		51 dB(A)
Reference air flow rate (m ³ /s)*		0,052 m ³ /s
Pressure difference (Pa)*		50 Pa
Specific power consumption (W/(m ³ /h))		0,35 W/(m ³ /h)
Control type		Centralized environmental control
Control coefficient		0,85
Leakage rate (%)	indoor outdoor recirculation	1,4% 2,2% Not applicable
Mixing rate (%)		Not applicable
Position and description of visual signal filter warning		Alarm displayed on remote display
Fresh air supply installation		Not applicable
Air flow sensitivity to variations pressure at + 20Pa and - 20Pa (%)		Not applicable
Internal / external air tightness (m ³ /h)		Not applicable
Annual electricity consumption (AEC) specific for a 100m ² dwelling (kWh of electricity /yr)**	Cold climate Mild climate Hot climate	895,4 kWh elettr./a 358,4 kWh elettr./a 313,4 kWh elettr./a
Annual heating saving specific for a 100m ² dwelling (kWh of primary energy /yr)**	Cold climate Mild climate Hot climate	8733,8 kWh en.prim./a 4464,5 kWh en.prim./a 2018,8 kWh en.prim./a

* as per regulation no. 1253/2014

** calculated as per regulation no. 1254/2014

*3 humidity, CO sensor, air quality, presence sensor...